

STD_MKY44MC01A_V1.4E



Motion control function LSI for CUnet

MKY44-MC01A

User's Manual

Note

1. The information in this manual is subject to change without prior notice. Before using this product, please confirm that this is the latest version of this manual.
2. Technical information in this manual, such as explanations and circuit examples, are references for this product. When actually using this product, always fully evaluate the entire system according to the design purpose based on considerations of peripheral circuits and the PC board environment. We assume no responsibility for any incompatibility between this product and your system.
3. We assume no responsibility whatsoever for any losses or damages arising from the use of the information, products, and circuits in this manual, or for infringement of patents and any other rights of a third party.
4. When using this product and the information and circuits in this manual, we do not guarantee the right to use any property rights, intellectual property rights, and any other rights of a third party.
5. This product is not designed for use in critical applications, such as life support systems. Contact us when considering such applications.
6. No part of this manual may be copied or reproduced in any form or by any means without prior written permission from StepTechnica Co., Ltd..

Preface

This manual describes about “MKY44-MC01A”, motion control function LSI for CUnet.

The description of this manual is based on the premise that you have already understood the overview of CUnet.

Be sure to read “*CUnet Introduction Guide*” before understanding this manual and the MKY44-MC01A.

● Target Readers

This manual is for:

- Those who use StepTechnica's MKY44-MC01A to build the application used a CUnet

● Prerequisites

This manual assumes that you are familiar with:

- Network technology
- Semiconductor products (especially microcontrollers and memory)

● Related Manuals

- CUnet Introduction Guide Issued by: StepTechnica
- CUnet Technical Guide Issued by: StepTechnica

[Caution]

Some terms in this manual are different from those used on our website and in our product brochures. The brochure uses ordinary terms to help many people in various industries understand our products.

Please understand technical information on HLS Family and CUnet Family based on technical documents (manuals).

CONTENTS

Chapter 1 Functions for Motion Control

1.1	Connection of MKY44-MC01A.....	1-3
1.2	Basic Instructions	1-4
1.2.1	Relationship between Basic Instructions and Parameters	1-4
1.2.2	Settable Speed	1-5
1.2.3	Setting Acceleration (Rate Format)	1-5
1.2.4	Setting Acceleration (Required Time Format).....	1-6
1.2.5	Parameter Auto Correction Function	1-7
1.2.6	Selecting Speed Transition Curve	1-7
1.2.7	256 Levels of Speed Transition.....	1-8
1.2.8	Operation by Combination of Basic Instructions	1-8
1.2.9	Errors from Combination of Basic Instructions.....	1-9
1.2.10	Intentional Triangular Drive.....	1-10
1.2.11	Triangular Drive Prevention Function	1-10
1.3	Move Instructions	1-12
1.3.1	Move Instruction to Specify Distance	1-13
1.3.2	Move Instruction to Specify Target	1-14
1.3.3	Parameters of Move Instructions	1-15
1.3.4	Timing to Receive Move Instructions.....	1-16
1.3.5	Operation of Move Instructions to Maintain Constant Speed.....	1-16
1.3.6	Trapezoidal Speed Control and Pattern	1-17
1.3.7	Relationship of Patterns	1-18
1.3.8	Pattern Reduction Function	1-19
1.3.9	Usage Specifying Only Distance	1-20
1.4	Origin Detection	1-21
1.4.1	Origin Search Instruction and Speed Transition.....	1-21
1.4.2	Three Origin Search Instructions and Their Detection Sensors	1-22
1.4.3	Usage Example of the Origin Search Instruction and Initialization of Logical Coordinate Value	1-23
1.5	Stop Functions	1-24
1.5.1	All Stop.....	1-25
1.5.2	DONA Stop.....	1-25
1.5.3	Stop Using Origin Sensor, EZ Sensor, and Stop Signal Input	1-25
1.5.4	Stop Using Stop Sensors and Hardware Limits.....	1-25
1.5.5	Physical Position Coordinate	1-26
1.5.6	Stop Setting Using Limit Coordinates	1-26
1.6	Pattern Memory and File	1-27
1.7	Synchronization of Operation Instructions	1-28
1.7.1	Synchronization Trigger	1-29
1.7.2	Synchronous Performance	1-29
1.7.3	Releasing Synchronization Wait State	1-29

1.8	Addressing Manual Operation	1-30
1.8.1	Continue Mode and Single Mode.....	1-30
1.8.2	Speed and Distance in Manual Operation	1-31
1.9	Utility Functions	1-32
1.9.1	Remote Reset from Applications.....	1-32
1.9.2	General-Purpose Input Pins/General-Purpose Output Pins	1-32
1.9.3	Output Signal Indicating Axis Operating	1-33
1.9.4	Do3 Watchdog Timer Function	1-33
1.9.5	Logical Inversion Function for Pins	1-34
1.9.6	Addressing DONA and Network Failure	1-35
1.10	Registers for Motion Control	1-36

Chapter 2 How to Use MKY44-MC01A

2.1	How to Access CUnet Interface and Registers	2-4
2.1.1	How to Read Registers	2-5
2.1.2	How to Write to Registers	2-6
2.1.3	Cautions in Write Operation.....	2-7
2.1.4	Cautions in Read Operation.....	2-8
2.1.5	Warnings and Notifications from MKY44-MC01A	2-9
2.1.5.1	Reset Warning State and How to Cancel It.....	2-9
2.1.5.2	CUnet Line Return Warning and How to Cancel It.....	2-10
2.1.5.3	Error Notification	2-10
2.1.5.4	Stop Notification (Optional)	2-11
2.1.5.5	Cautions for Warnings and Notifications	2-11
2.1.6	Extended CUnet Interface (Optional)	2-12
2.1.7	Processing Order of Access	2-13
2.1.8	Warnings of Setting Mistakes of SA and DOSA	2-13
2.2	Internal Registers of MKY44-MC01A	2-14
2.2.1	Register Structure of Motion Control and Port 2 Control	2-15
2.2.2	Write-Protected Registers	2-16
2.2.3	Descriptions of Registers for Motion Control	2-17
2.2.3.1	Description of Register AXS	2-17
2.2.3.2	Description of Register LPC	2-18
2.2.3.3	Description of Register PPC	2-18
2.2.3.4	Description of Register NS	2-18
2.2.3.5	Description of Register COM	2-19
2.2.3.6	Description of Register TPC	2-20
2.2.3.7	Description of Register RAD.....	2-20
2.2.3.8	Descriptions of Registers LS and US	2-21
2.2.3.9	Description of Register ACC.....	2-21
2.2.3.10	Description of Register SCom	2-22
2.2.3.11	Description of Register STS	2-22
2.2.3.12	Description of Registers PLC and MLC	2-23

2.2.3.13	Description of Register PG1	2-23
2.2.3.14	Description of Register PG2	2-24
2.2.3.15	Description of Register P2C	2-26
2.2.3.16	Description of Register P2I	2-27
2.2.4	Initial Values of Registers.....	2-28
2.3	Commands of MKY44-MC01A.....	2-29
2.3.1	Commands to Control Motion.....	2-30
2.3.2	Commands to Set Data in General-Purpose Output Pins	2-30
2.3.3	Data Setting Commands for Write-Protected Registers.....	2-30
2.3.4	Operation Commands of Pattern Memory	2-31
2.3.5	Synchronization Commands.....	2-32
2.4	Errors and Error Notification	2-33
2.5	Motion Events.....	2-35
2.6	Exceptional Operation	2-36
2.7	Operation Procedure of MKY44-MC01A.....	2-37
2.7.1	Process after Power-on and Return from Reset	2-37
2.7.2	Confirming Chip Codes	2-37
2.7.3	Initializing the Registers for Motion Control	2-38
2.7.4	Initializing the Application Device	2-38
2.7.5	Normal Operation.....	2-38
2.7.6	Exit Operation.....	2-38
2.8	Addressing CUnet Mail Function.....	2-39

Chapter 3 MKY44-MC01A Hardware

3.1	Pin Functions of MKY44-MC01A.....	3-4
3.2	Electrical Ratings of Pins	3-6
3.3	Pin Assignment	3-8
3.4	Connection of Basic I/O Signals.....	3-9
3.4.1	Supply of Drive Clocks	3-9
3.4.2	Supply of Hardware Reset Signal.....	3-9
3.4.3	Connection of Signal for Hardware Setting (Hexadecimal Setting Specifications).....	3-10
3.4.4	Connection of Signal for Hardware Setting (Decimal Setting Specifications)	3-11
3.5	Connection of CUnet-related I/O Signals.....	3-12
3.5.1	Recommended Network Connection	3-12
3.5.2	Connection and Displayed States of LED Indicator Pins.....	3-13
3.5.3	PING Signal.....	3-14
3.5.4	CYCT signal	3-14
3.6	I/O Signal of Axis Control Unit.....	3-15
3.6.1	Connection of Motion Control Output Signals.....	3-15
3.6.2	Input Signal Connection for Physical Position Coordinates	3-17
3.6.3	Input Signal of Sensors	3-18
3.6.4	General-Purpose Input for Axis Control (#Di0 to #Di3)	3-18
3.6.5	General-Purpose Output for Axis Control (Do0 to Do3).....	3-19

3.6.6	General-purpose I/O Pin without Shared Functions.....	3-19
3.7	Example of Connection Circuit.....	3-20
3.8	Electrical Ratings	3-21
3.9	Package Dimensions	3-22
3.10	Recommended Soldering Conditions	3-23
3.11	Recommended Reflow Conditions.....	3-23

Appendix

Appendix 1	CUnet Cycle Time Table	App-3
Appendix 2	File Contents of Flash ROM in Factory Default Setting	App-4

Figures

Fig. 1.1	Connection of MKY44-MC01A.....	1-3
Fig. 1.2	Method of Setting the Required Time	1-6
Fig. 1.3	Curve Selection	1-7
Fig. 1.4	256 Levels of Speed Transition.....	1-8
Fig. 1.5	Driving by Combination of Basic Instructions	1-8
Fig. 1.6	Examples of Intentional Triangular Drive	1-10
Fig. 1.7	Triangular Drive Prevention with Peak Keep Time	1-10
Fig. 1.8	Driving Slide Table	1-12
Fig. 1.9	Up/Down Counter Comprising Logical Position Coordinates	1-12
Fig. 1.10	Examples of Move Instructions Specifying Distance	1-13
Fig. 1.11	Examples of Move Instructions Specifying Target	1-14
Fig. 1.12	Move Instructions to Maintain Constant Speed	1-16
Fig. 1.13	Trapezoidal Speed Control.....	1-17
Fig. 1.14	Relationships between Distance and Patterns	1-18
Fig. 1.15	Pattern Reduction	1-19
Fig. 1.16	Speed Transition of Origin Search	1-21
Fig. 1.17	Stop by Detecting the Sensor of Origin Search 1	1-22
Fig. 1.18	Stop by Detecting the Sensor of Origin Search 2.....	1-22
Fig. 1.19	Usage Example of Origin Search Instruction	1-23
Fig. 1.20	Sensors and Signals of Stop System.....	1-24
Fig. 1.21	Up/Down Counter Comprising Physical Position Coordinates	1-26
Fig. 1.22	Pattern Memory	1-27
Fig. 1.23	Example of Operation Instruction	1-28
Fig. 1.24	Continue Mode and Single Mode.....	1-30
Fig. 1.25	Timing of DONA.....	1-35
Fig. 2.1	CUNet I/F Image	2-4
Fig. 2.2	How to Write	2-6
Fig. 2.3	Extended Interface	2-12
Fig. 2.4	Register Numbers and Registers	2-14
Fig. 2.5	Register Structure of Motion Control and Port 2 Control	2-15
Fig. 2.6	Data Format of Remote Reset.....	2-36
Fig. 3.1	Block Diagram of MKY44-MC01A	3-3
Fig. 3.2	Pin electrical characteristics in I/O circuit types of MKY44-MC01A.....	3-7
Fig. 3.3	Signal Assignment of MKY44-MC01A Pins.....	3-8
Fig. 3.4	Connection of DIP-SW and Read-Only LSI (Hexadecimal Setting Specifications)	3-10
Fig. 3.5	Connection of DIP-SW and Read-only LSI (Decimal Setting Specifications).....	3-11
Fig. 3.6	Recommended Network Connection	3-12
Fig. 3.7	Example Output Circuit to Ensure Initial Low-level	3-15
Fig. 3.8	Motion Control Output Signal of Positive/Negative Rotation	3-16
Fig. 3.9	Example of Circuit Conversion for CW and CCW Pulse Format	3-16
Fig. 3.10	Example of Circuit Conversion from Phase Signal Format	3-17
Fig. 3.11	Example of MKY44-MC01A Circuit Connection.....	3-20

Tables

Table 1-1	Move Instructions	1-3
Table 1-2	Parameters Required for Basic Instructions	1-4
Table 1-3	Speed Range and Corresponding Speed	1-5
Table 1-4	Settable Acceleration.....	1-5
Table 1-5	Example of Setting Acceleration Using Required Time Format	1-6
Table 1-6	Combinations of Basic Operation Instructions.....	1-9
Table 1-7	Combinations of Basic Instructions when Triangular Drive Function is ON	1-11
Table 1-8	Parameters Required for Move Instructions	1-15
Table 1-9	Auto Start Enable Function.....	1-20
Table 1-10	Origin Search Instructions and Target Sensors.....	1-22
Table 1-11	Factory Default Setting of Stop Functions	1-24
Table 1-12	Synchronization Performance	1-29
Table 1-13	Addressing Manual Operation	1-31
Table 1-14	General-Purpose I/O Pins and Convertible Functions	1-32
Table 1-15	Pins Settable for Logical Inversion	1-34
Table 1-16	Registers for Motion Control	1-36
Table 2-1	Description of AXS.....	2-17
Table 2-2	Description of COM.....	2-19
Table 2-3	Description of SCom.....	2-22
Table 2-4	Settings of PG1	2-23
Table 2-5	Factory Default Settings of PG1	2-23
Table 2-6	Settings of PG2	2-24
Table 2-7	Factory Default Settings of PG2	2-25
Table 2-8	Description of P2C	2-26
Table 2-9	Settings of P2I	2-27
Table 2-10	Initial Value of Each Register after Returning from Reset	2-28
Table 2-11	List of Commands.....	2-29
Table 2-12	List of Synchronization Commands.....	2-32
Table 2-13	List of Error Codes.....	2-33
Table 2-14	List of Motion Event Codes.....	2-35
Table 3-1	Pin Functions of MKY44-MC01A.....	3-4
Table 3-2	Electrical Ratings of MKY44-MC01A	3-6
Table 3-3	Settings of the DIP-SW Connected to ST44SW of Hexadecimal Setting Specifications	3-10
Table 3-4	States of MKY44-MC01A Displayed by LED Indicators	3-13
Table 3-5	General-Purpose I/O Pin and Shared Functions	3-18
Table 3-6	Absolute Maximum Ratings	3-21
Table 3-7	Electrical Ratings	3-21

Chapter 1 Functions for Motion Control

This chapter describes the functions for motion control provided by MKY44-MC01A.

- 1.1 Connection of MKY44-MC01A..... 1-3
- 1.2 Basic Instructions 1-4
- 1.3 Move Instructions..... 1-12
- 1.4 Origin Detection 1-21
- 1.5 Stop Functions 1-24
- 1.6 Pattern Memory and File..... 1-27
- 1.7 Synchronization of Operation Instructions 1-28
- 1.8 Addressing Manual Operation 1-30
- 1.9 Utility Functions 1-32
- 1.10 Registers for Motion Control..... 1-36

Chapter 1 Functions for Motion Control

This chapter describes the functions for motion control provided by MKY44-MC01A. As this chapter focuses on the concepts of functions and description of operations, please refer to the other chapters regarding actual use after understanding this chapter.

1.1 Connection of MKY44-MC01A

CUnet is a network that can connect multiple devices. MKY44-MC01A is a CUnet-dedicated LSI for motion control with the function to output pulse signals to drive a stepping motor or such.

MKY44-MC01A is connected between CUnet and a motor driver (motor amplifier) (see Figure 1.1).

MKY44-MC01A controls basic instructions and move instructions received from CUnet (see Table 1-1).

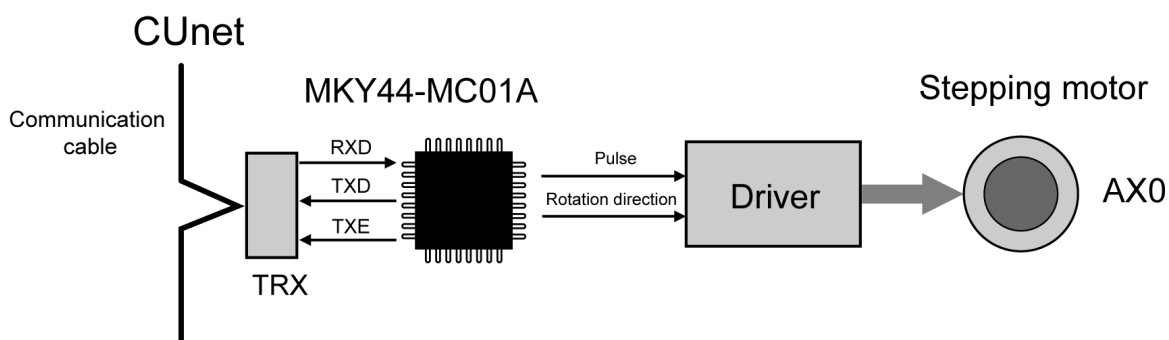

Fig. 1.1 Connection of MKY44-MC01A

Table 1-1 Move Instructions

	Instruction	Name	Actual operation
Basic instructions	Select Direction	CW, CCW	Select rotation direction. This operation can be executed only while stopped.
	Stop	Quick_Stop	Stop pulse output.
	Lower Speed	LFlat	Start pulse output at equal intervals corresponding to the lower speed.
	Upper Speed	UFlat	Start pulse output at equal intervals corresponding to the upper speed.
	Accelerate	P_Accele	Change the pulse output speed from the lower speed to the upper speed if stopped or from the current speed to the upper speed if during operation.
	Decelerate	M_Accele	Change the pulse output speed from the current speed to the lower speed.
	Deceleration Stop	MA_Stop	Stop pulse output after changing the pulse output speed from the current speed to the lower speed.
Move instructions	Distance specification pattern movement	DS_Pattern	Output pulse of specified distance by changing the speed from stop to acceleration, constant upper speed, and deceleration stop.
	Distance specification lower speed movement	DS_LFlat	Output pulse at equal intervals corresponding to the lower speed, equivalent to the specified distance.
	Distance specification upper speed movement	DS_UFlat	Output pulse at equal intervals corresponding to the upper speed, equivalent to the specified distance.
	Target specification pattern movement	TS_Pattern	Output pulse to the target position coordinate by changing the speed from stop to acceleration, constant upper speed, and deceleration stop.
	Target specification lower speed movement	TS_LFlat	Output pulse at equal intervals corresponding to the lower speed. The number of pulses output is equivalent to the distance to the target position coordinate.
	Target specification upper speed movement	TS_UFlat	Output pulse at equal intervals corresponding to the upper speed. The number of pulses output is equivalent to the distance to the target position coordinate.
	Origin detection	OriginSearch	Output the automatically calculated number of pulses to the origin orientation. Pulse output stops upon sensor detection.

1.2 Basic Instructions

This section describes basic instructions controlling axes.

1.2.1 Relationship between Basic Instructions and Parameters

There are seven basic instructions including Select Direction, Stop, Lower Speed, Upper Speed, Accelerate, Decelerate, and Deceleration Stop. The parameters required for these instructions are lower speed, upper speed, acceleration, and direction (see Table 1-2).

Table 1-2 Parameters Required for Basic Instructions

Instruction	Name	Lower speed	Upper Speed	Acceleration	Direction
Select Direction	CW, CCW	---	---	---	---
Stop	Quick_Stop	---	---	---	---
Lower Speed	LFlat	○	---	---	○
Upper Speed	UFlat	---	○	---	○
Accelerate	P_Accele	△	○	○	△
Decelerate	M_Accele	○	---	○	□
Deceleration Stop	MA_Stop	○	---	○	□

○: A parameter is required to execute the instruction.

△: Required to start the operation of a stopped axis with the Accelerate instruction.
When it is already operating, the current set value applies.

□: The current set value applies since the execution of the instruction is enabled only during operation.

These seven basic instructions will not be executed unless all the required parameters are newly set. The parameters set previously can be used again if changes are not necessary.

The parameters of lower speed, upper speed, and acceleration can be rewritten to prepare for the next instruction even during instruction execution.



When “Deceleration Stop” is selected as the stop style for MKY44-MC01A, rewriting the parameters of lower speed and acceleration is disabled during operation. In such a case, if the lower speed parameter is rewritten mistakenly, an error showing that it is disabled will occur. For more information about stop type, see “**1.5 Stop Functions**”.

1.2.2 Settable Speed

MKY44-MC01A has three speed ranges, as shown in Table 1-3. The speed range should be selected while the axis is stopped. It is generally recommended to select it at the initial setting of the system.

The parameters of lower speed and upper speed can be set flexibly in units of 1 pps within the selected range.

Table 1-3 Speed Range and Corresponding Speed

Speed range	Corresponding speed
2, 3	160 pps to 24 kpps
1	40 pps to 10.0 kpps
0	10 pps to 2.5 kpps

MKY44-MC01A doesn't have the concept of "magnification" commonly seen in 1-chip type pulse generator LSIs. For example, when the speed range from 160 pps to 24 kpps is selected, the lower speed can be set as 234 pps and the upper speed can be set as 8,765 pps. This is useful for speed specification avoiding mechanical resonance and for speed specification in flow control.



Reference

The precision of speed setting of MKY44-MC01A is within $\pm 0.3\%$.
The factory default speed range is "2 (160 pps to 24 kpps)".

1.2.3 Setting Acceleration (Rate Format)

Although acceleration is commonly represented as "the amount of speed change in a second (pps/sec or pps²)", With MKY44-MC01A, the value is set as "the amount of speed change in 10 ms (pps/10 ms)" (see Table 1-4).

Acceleration includes plus acceleration (acceleration) in which the speed transitions to the upper speed and minus acceleration (deceleration) in which the speed transitions to the lower speed. Plus acceleration and minus acceleration can be set individually. The values that can be set with MKY44-MC01A are 1 to 1,542.

If the required time (speed transition width ÷ rate) for speed transition exceeds 40.95 seconds when acceleration is very slow and speed transition width is large, the acceleration will be set for 40.95 seconds. Also, if the acceleration is high and the required time for speed transition is less than 80 ms when executing acceleration/deceleration in which the upper speed is lower than or equal to 22 kpps, an error will occur. Likewise, if the upper speed is more than 22 kpps, an error will occur when the required time for speed transition is less than 90 ms.

Table 1-4 Settable Acceleration

MKY44-MC01 setting value (pps/10 ms)	Common acceleration indication (pps/sec)	Reference indication (ms/kHz)
---	to 99	---
1	100	10,000
2	200	5,000
5	500	2,000
10	1 K	1,000
20	2 K	500
50	5 K	200
100	10 K	100
200	20 K	50
500	50 K	20
1,000	100 K	10
1,542	154.2 K	≈6.5
---	154.3 K to	---



Reference

Even if the required time for speed transition is less than 80 ms or 90 ms, an error will not occur when the function described in "1.2.5 Parameter Auto Correction Function" is on; the acceleration will be forced so that the required time for speed transition is 80 ms or 90 ms.

1.2.4 Setting Acceleration (Required Time Format)

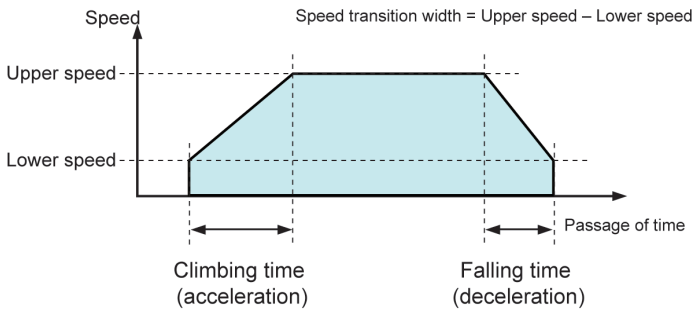

The time to transition between the upper speed and the lower speed, i.e. the required climbing time (acceleration) and falling time (deceleration), can be used as a format for setting acceleration (see Figure 1.2). In the factory default setting, rate format is selected instead of required time format. To use values in the required time format, set the ARTS (Acceleration Rate/Time Select) bit of the PG2 (Property Group 2) register.

Fig. 1.2 Method of Setting the Required Time

In this setting, values with units of 10 ms are set. For example, set “100” for “1 second” and set “1,000” for “10 seconds”. Plus acceleration and minus acceleration can be set individually, just like the standard method. The values that can be set regardless of upper speed are 8 to 4,095 (0.08 seconds to 40.95 seconds). To illustrate this method, settings where the transition width is 8 kpps or 12.34 kpps are shown in Table 1-5. This setting method is easy to use for changing speed gently within a predetermined range, such as for flow control, including air and water flows.

In this setting, values with units of 10 ms are set. For example, set “100” for “1 second”

Table 1-5 Example of Setting Acceleration Using Required Time Format

When the acceleration is from 500 pps (lower speed) to 8.5 kpps (upper speed) (500 to 8.5 kpps: Δ8,000 pps)		When the acceleration is from 160 pps (lower speed) to 12.5 kpps (upper speed) (160 to 12.5 kpps: Δ12,340 pps)		Reference indication		
Transition time	Setting value	Transition time	Setting value	pps/10 ms	pps/sec	ms/kHz
*40.95 seconds	4,095 (0xFF5)	*40.95 seconds	4,095 (0xFF5)	---	to 99	---
*40.95 seconds	4,095 (0xFF5)	*40.95 seconds	4,095 (0xFF5)	1	100	10,000
40.00 seconds	4,000 (0xFA0)	*40.95 seconds	4,095 (0xFF5)	2	200	5,000
---	---	40.95 seconds	4,095 (0xFF5)	≈3	≈300	≈3,000
16.00 seconds	1,600(0x640)	24.68 seconds	2,468 (0x9A4)	5	500	2,000
8.00 seconds	800 (0x320)	12.34 seconds	1,234 (0x4D2)	10	1 K	1,000
4.00 seconds	400 (0x190)	6.17 seconds	617 (0x269)	20	2 K	500
1.60 seconds	160 (0x0A0)	≈2.47 seconds	247 (0x0F7)	50	5 K	200
0.80 seconds	80 (0x050)	≈1.23 seconds	123 (0x07B)	100	10 K	100
0.4 seconds (400 ms)	40 (0x028)	≈0.62 seconds (620 ms)	62 (0x03E)	200	20 K	50
0.16 seconds (160 ms)	16 (0x010)	≈0.25 seconds (250 ms)	25 (0x019)	500	50 K	20
0.08 seconds (80 ms)	8 (0x008)	≈0.12 seconds (120 ms)	12 (0x00C)	1,000	100 K	10
---	---	≈0.08 seconds (80 ms)	8 (0x008)	1,542	154.2 K	≈6.5
---	---	---	---	---	154.3 K up	---

Reference

When the upper speed is lower than or equal to 11 kpps, “7 (70 ms: 0.07 seconds)” can be set as the minimum time.
 When the upper speed is lower than or equal to 8 kpps, “6 (60 ms: 0.06 seconds)” can be set as the minimum time.
 When the upper speed is lower than or equal to 5 kpps, “5 (50 ms: 0.05 seconds)” can be set as the minimum time.
 In the factory default setting, the required time format is not selected. In the table, “*” indicates the maximum settable value.

1.2.5 Parameter Auto Correction Function

If the acceleration setting of MKY44-MC01A goes out of the controllable range, whether in the standard rate format or the optional required time format, an error will occur when an operation instruction is received. It is the same when the setting of upper speed and lower speed is inappropriate.

In such a case, there is a “parameter auto correction function” that can automatically correct the setting into the controllable range without causing any errors. For example, when the speed range is “2”, an error will occur if “40 pps” is mistakenly set as the lower speed. However, if the “parameter auto correction function” is on, the lower speed setting will be changed automatically to “160 pps”, which is the minimum value of the “2” speed range. In this way, the function affects the parameter values of speed and acceleration.

When the speed transition width is less than “32” in the basic instructions Accelerate, Decelerate, and Deceleration Stop, an error will occur even if “parameter auto correction function” is selected because the transition width is too narrow. However, when the speed transition width is less than “32” in pattern move instructions, described later, an error will not occur if “parameter auto correction function” is selected. This is because the operation will be corrected automatically to the move instruction without speed transition by lower speed.

Turn ON or OFF the “parameter auto correction function” using the PAC (Parameter Auto Correction) bit of the PG2 (Property Group 2) register.



Reference

If a speed error occurs, the details will be shown by an error code.

For details on error codes, see “2.4 Errors and Error Notification”.

The parameter auto correction function is ON in the factory default setting.

1.2.6 Selecting Speed Transition Curve

In MKY44-MC01A, a straight line or S-curve can be selected for the speed transition of acceleration and deceleration (see Figure 1.3).

The speed transition curve needs to be selected while stopped. It is generally recommended to select it at the initial setting of the system. In MKY44-MC01A, it is not possible to set acceleration and deceleration differently, e.g. “straight line for acceleration and S-curve for deceleration”. Set the speed transition using the CS (Curve Select) bit of the PG1 (Property Group 1) register.

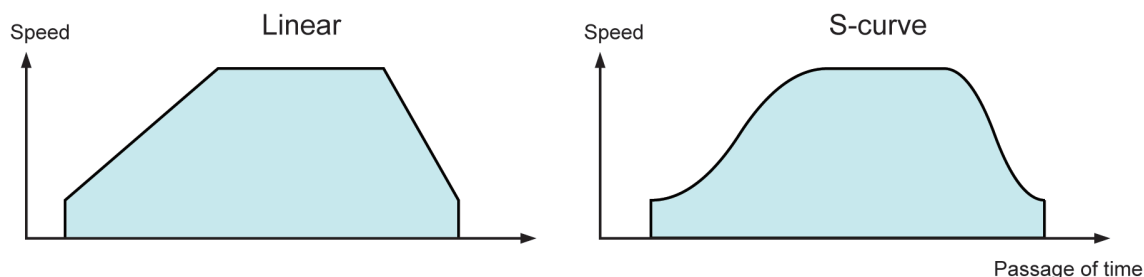

Fig. 1.3 Curve Selection



Reference

S-curve is set in the factory default setting.

1.2.7 256 Levels of Speed Transition

The speed change between upper speed and lower speed in MKY44-MC01A has 256 levels with constant transition time. For example, if the lower speed is set to 123 pps and the upper speed is set to 9,876 pps in an S-curve with an acceleration rate of 5 kpps/sec (or acceleration required time of 1,950 ms) and an deceleration rate of 25 kpps/sec (or acceleration required time of 390 ms), it will take 256 levels of transition to the target speed for both acceleration and deceleration. This makes speed transition smooth regardless of the setting value (see Figure 1.4).

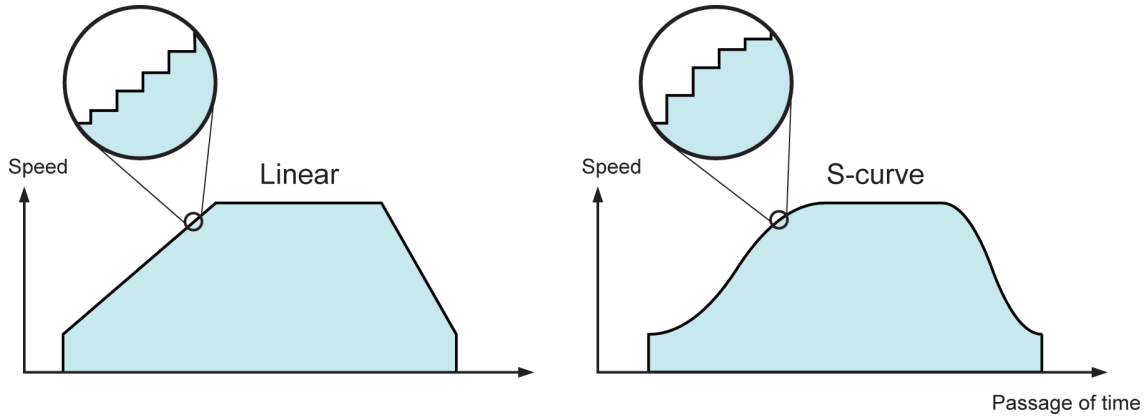

Fig. 1.4 256 Levels of Speed Transition

 **Reference**

To address a deceleration instruction while accelerating, it will decelerate by the same number of levels used by acceleration because the speed transition width is not the width between the upper speed and the lower speed. It is the same for addressing an acceleration instruction while decelerating.

1.2.8 Operation by Combination of Basic Instructions

Basic instructions can be used in serial combination. Figure 1.5 shows an example.

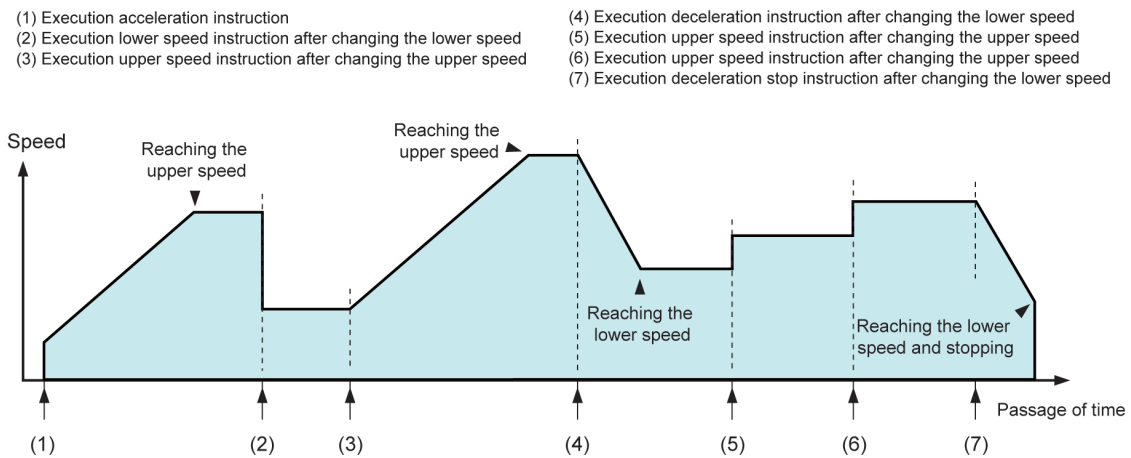

Fig. 1.5 Driving by Combination of Basic Instructions

1.2.9 Errors from Combination of Basic Instructions

MKY44-MC01A defines importance in the order “Stop > Deceleration Stop > Other instructions”. Therefore, when it receives a “Stop” instruction, it will stop regardless of operation status (see Table 1-6).

The “Deceleration Stop” instruction comes right next to the “Stop” instruction in importance. While performing the deceleration, an important stop process in the “Deceleration Stop” instruction, other instructions such as “Lower Speed”, “Upper Speed”, “Accelerate”, and “Decelerate” will not be accepted but cause an error. With MKY44-MC01A, an error will occur for some combinations, such as “Accelerate” instructions while accelerating. Errors caused by ×-marked operations in Table 1-6 are only to notify that instructions will not be accepted. They will not affect operations in execution.

Table 1-6 Combinations of Basic Operation Instructions

Instruction	At upper speed At lower speed	While accelerating	While decelerating	While decelerating by deceleration stop instruction	While stopped
Select Direction	×	×	×	×	○
Stop	○	○	○	○	○
Lower Speed	○	○	○	×	○
Upper Speed	○	○	○	×	○
Accelerate	○	×	○	×	○
Decelerate	○	○	×	×	×
Deceleration Stop	○	○	□	□	×

○: Can be executed.

□: Stop as soon as deceleration ends: already decelerating.

×: An error will occur and the instructions will not be executed. It will not affect operations in execution.



Reference

If an error occurs, the details will be shown by an error code.

For details on error codes, see “**2.4 Errors and Error Notification**”.

1.2.10 Intentional Triangular Drive

By executing the “Decelerate” instruction while accelerating, you can intentionally execute a triangular drive which forms an angle at the upper speed side. Similarly, by executing the “Accelerate” instruction while decelerating, you can intentionally execute a triangular drive which forms an angle at the lower speed side (see Figure 1.6). These intentional triangular drives can be used to effectively control some mechanisms.

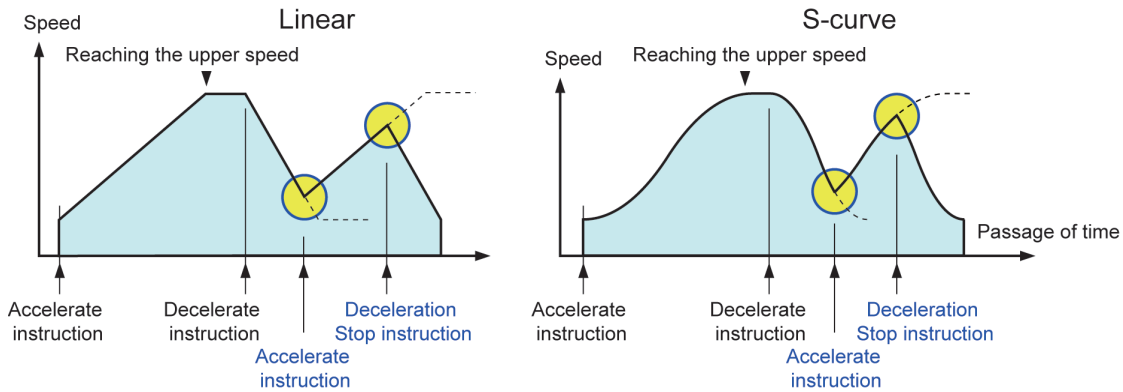

Fig. 1.6 Examples of Intentional Triangular Drive

1.2.11 Triangular Drive Prevention Function

If a machine is shifted to deceleration while it is still accelerating, the drive systems such as motors, gear boxes, and actuators may be overloaded. Therefore, it is generally required to prevent this except for some applications that allow triangular drive.

MKY44-MC01A can insert “Peak Keep Time”, which can retain the speed at which triangular drive occurs for a certain period of time (see Figure 1.7). As well as during acceleration and deceleration, “Peak Keep Time” can be applied at the upper speed after acceleration, at the lower speed after deceleration, and while stopped after deceleration stop. Peak Keep Time can be set in units of 10 ms up to 10.23 seconds (0x3FF) with the PKTS (Peak Keep Time Setup) bit of the PG1 (Property Group 1) register. The setting of Peak Keep Time as “0” is the OFF state of the triangular drive prevention function. The factory default setting is OFF.

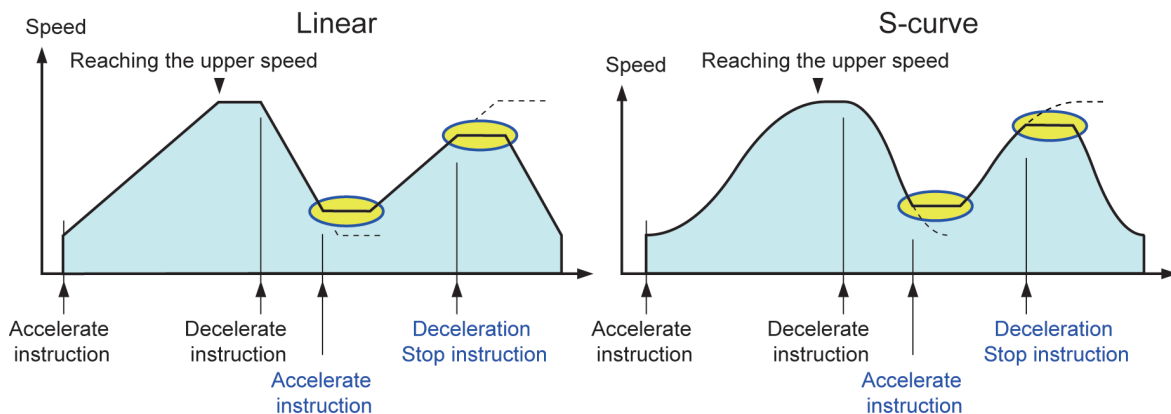

Fig. 1.7 Triangular Drive Prevention with Peak Keep Time

The combinations of basic instructions when a value other than “0” is set in Peak Keep Time and the triangular drive prevention function is ON are shown in Table 1-7.

When the triangular drive prevention function is ON, it will start a deceleration stop operation after the time necessary for forming “Peak Keep Time” is inserted, even if the “Deceleration Stop” instruction is received or the limit coordinate set as the start position of deceleration stop is reached while accelerating or at the upper speed after acceleration. Also, an error will occur if the “Accelerate” instruction is received before the end of “Peak Keep Time” after deceleration stop. Therefore, it is recommended not to set “Peak Keep Time” unnecessarily long.

Table 1-7 Combinations of Basic Instructions when Triangular Drive Function is ON

Instruction	At upper speed At lower speed	While accelerating	While decelerating	While decelerating by deceleration stop instruction	While stopped
Select Direction	×	×	×	×	○
Stop	○	○	○	○	○
Lower Speed	○	○	○	×	○
Upper Speed	○	○	○	×	○
Accelerate	○ (▲)	×	▲	×	○ (×)
Decelerate	○ (▼)	▼	×	×	×
Deceleration Stop	○ (▼)	▼	□	□	×

○: Can be executed.

□: Stop as soon as deceleration ends: already decelerating.

×: An error will occur and the instructions will not be executed.

▲: If the time at constant speed is shorter than the time set for Peak Keep Time at the point in time when a instruction is received, it will start accelerating after inserting enough time to form Peak Keep Time.

▼: If the time at constant speed is shorter than the time set for Peak Keep Time at the point in time when a instruction is received, it will start decelerating after inserting enough time to form Peak Keep Time.

1.3 Move Instructions

This section describes move instructions.

Most applications using stepping motors manage and control the number of rotations of the motors and the distance of the actuators driven by the motors. For example, to drive a slide table using a stepping motor, positive rotation of the motor moves the table in the positive direction the same distance the motor rotates. Conversely, negative rotation of the motor moves the table in the negative direction the same distance the motor rotates (see Figure 1.8).

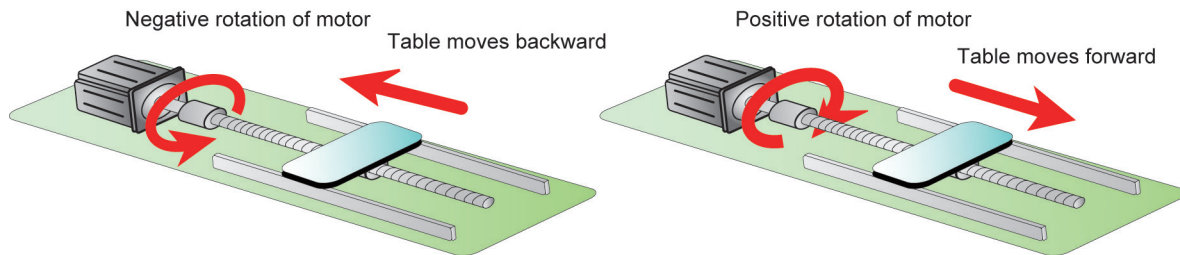

Fig. 1.8 Driving Slide Table

In such an application, the signal of rotation direction output by MKY44-MC01A moves the table in a certain direction, and the pulse count output by MKY44-MC01A corresponds to the distance of the table. If an Up/Down counter is set up by adding the pulse count when the rotation direction is positive (CW: ClockWise) and subtracting the pulse count when it is negative (CCW: CounterClockWise), the value of the Up/Down counter will correspond to the coordinate of the table position (see Figure 1.9).

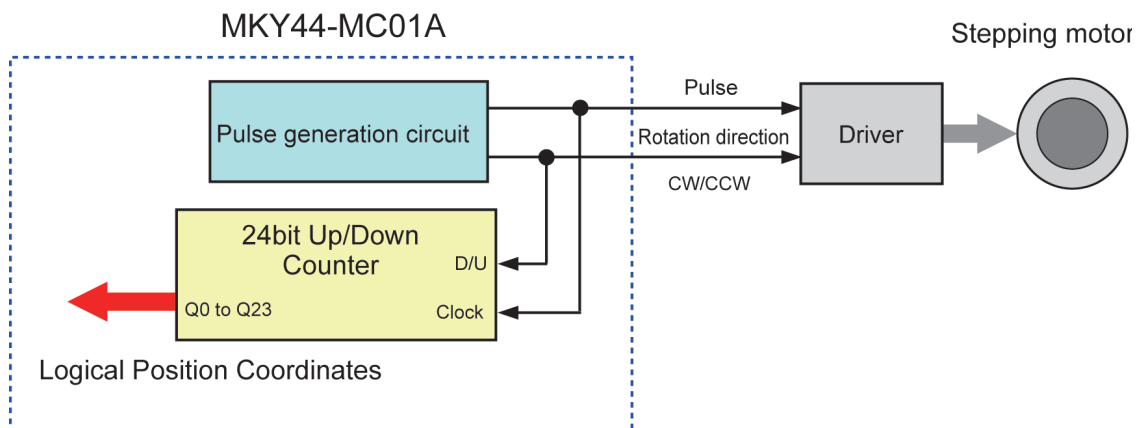

Fig. 1.9 Up/Down Counter Comprising Logical Position Coordinates

MKY44-MC01A has an Up/Down counter that can create coordinates from the number of pulse signals output by the LSI. The value of this counter is called “Logical Position Coordinates” (LPC).

Since the Up/Down counter of MKY44-MC01A is 24-bit, signed, the available coordinate values are “-8,388,608 to 8,388,607 (0x800000 to 0x7FFFFFF)”. There are two types of move instructions that can take specifications of distance and target position based on these “logical position coordinates” in MKY44-MC01A.

1.3.1 Move Instruction to Specify Distance

One of the two types of move instructions is Distance Specification (DS), which specifies “how much distance to move” relative to the current logical position coordinates. This type of instruction includes the following three movements.

1. Distance specification pattern movement (DS_Pattern)
2. Distance specification lower speed movement (DS_LFlat)
3. Distance specification upper speed movement (DS_UFlat)

There are two types of distance, “Relative Distance (RD)” and “Absolute Distance (AD)”. Both types provide 24-bit numerical parameters to MKY44-MC01A. “Relative

Distance” can handle the numerical values of “-8,388,608 to 8,388,607 (0x800000 to 0x7FFFFFF)” since it is signed to indicate positive or negative direction. “Absolute Distance” can handle “0 to 16,777,215 (0x000000 to 0xFFFFFFFF)”, since it is unsigned. The usage of instructions specifying distance is illustrated in Figure 1.10.

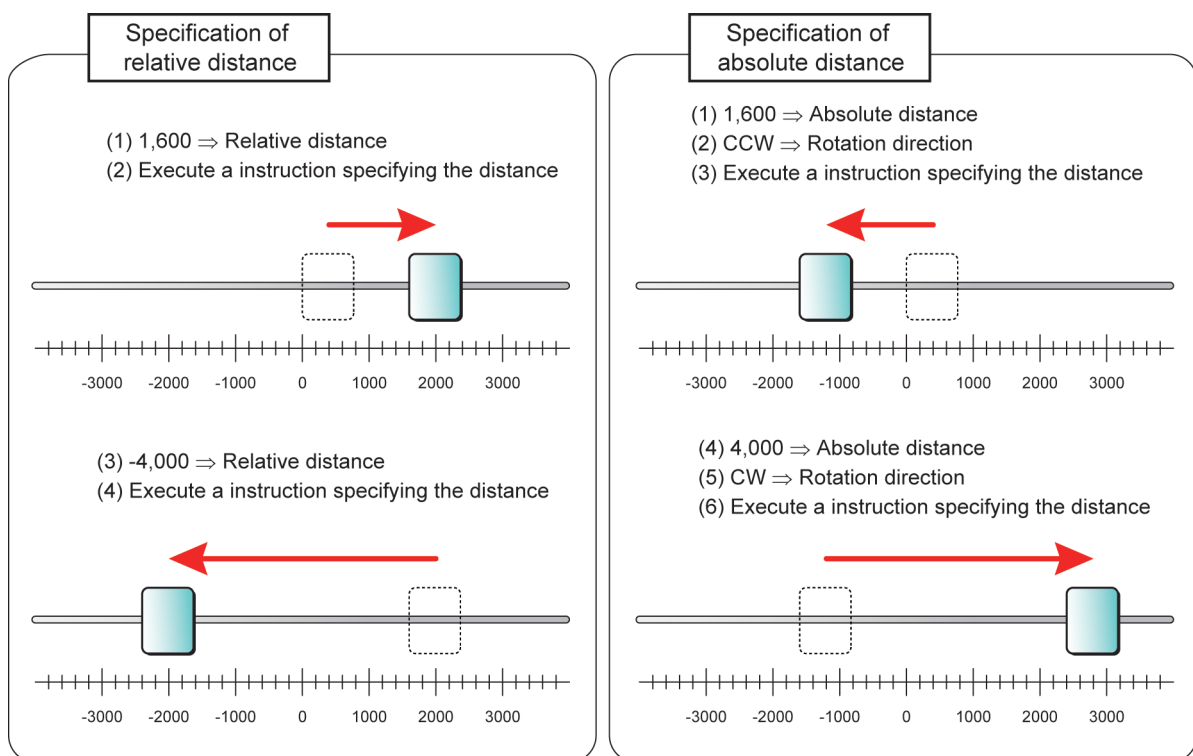

Fig. 1.10 Examples of Move Instructions Specifying Distance

When specifying distance, you need to set whether to use “relative distance” or “absolute distance” beforehand using the RADS (Relative/Absolute Distance Select) bit of the PG2 (Property Group 2) register. It is generally recommended to select it at the initial setting of the system.

If the position reached from specifying the distance exceeds the controllable range of logical position coordinates, an error will occur.

However, in applications such as controlling a rotating system that constantly rotates in a certain direction, this error is inappropriate. Therefore, you can select an option that enables over-scale distance so there will be no error even if the position reached exceeds the controllable range of logical position coordinates. It can be set with the OSE (Over Scale Enable) bit of the PG2 register.



Reference

“Relative distance” is selected in the factory default setting. Over-scale distance is disabled in this setting.

1.3.2 Move Instruction to Specify Target

The other type of move instruction is Target Specification (TS), which specifies “Target Position Coordinates”. This type of instruction includes the following three movements.

1. Target specification pattern movement (TS_Pattern)
2. Target specification lower speed movement (TS_LFlat)
3. Target specification upper speed movement (TS_UFlat)

The numerical values that can be handled by “Target Position Coordinates (TPC)” are the same as “Logical Position Coordinates”, “-8,388,608 to 8,388,607 (0x800000 to

0x7FFFFFFF)”. Since rotation direction is naturally determined in move instructions specifying the target, there is no need to set the rotation direction.

The usage of instructions specifying target is illustrated in Figure 1.11.

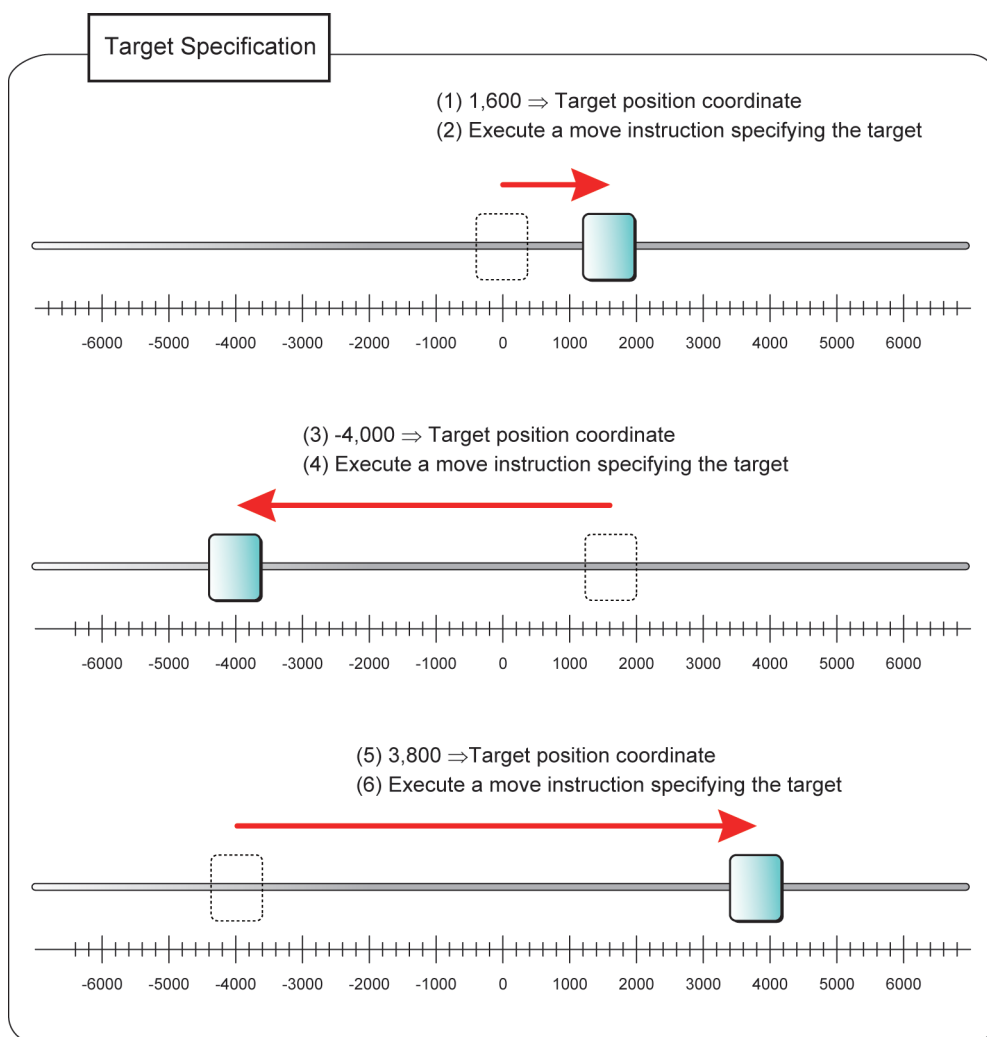

Fig. 1.11 Examples of Move Instructions Specifying Target

1.3.3 Parameters of Move Instructions

Table 1-8 shows the parameters required for move instructions.

Table 1-8 Parameters Required for Move Instructions

	Instruction	Name	Relative distance Target position coordinates	Target position coordinates	Lower speed	Upper speed	Acceleration	Direction
Move instructions	Distance specification pattern movement	DS_Pattern	○	---	○	○	○	RD : --- AD : ○
	Distance specification lower speed movement	DS_LFlat	○	---	○	---	---	RD : --- AD : ○
	Distance specification upper speed movement	DS_UFlat	○	---	---	○	---	RD : --- AD : ○
	Target specification pattern movement	TS_Pattern	---	○	○	○	○	---
	Target specification lower speed movement	TS_LFlat	---	○	○	---	---	---
	Target specification upper speed movement	TS_UFlat	---	○	---	○	---	---

Direction column

RD: Relative Distance specification
AD: Absolute Distance specification

This doesn't mean that instructions will not be executed unless all the required parameters are newly set. The parameters set previously can be used again if changes are not necessary.

However, if instructions specifying target are issued serially without changing the “target position coordinates”, an error shows that no movement will occur. In contrast, instructions specifying distance can be executed serially without changing any parameters.

Although direction parameters are necessarily determined in instructions specifying target and move instructions specifying “Relative Distance (RD)”, a setting is required to execute move instructions using “Absolute Distance (AD)”.

The parameters of relative distance, absolute distance, target position coordinate, lower speed, upper speed, and acceleration can be rewritten to prepare for the next instruction even during instruction execution.



Reference

When “Deceleration Stop” is selected as a stop type option for MKY44-MC01A, rewriting the parameters of lower speed and acceleration is disabled during operation. In such a case, if the lower speed parameter is rewritten mistakenly, an error showing that it is disabled will occur. For more information about stop type, see “1.5 Stop Functions”.

1.3.4 Timing to Receive Move Instructions

The basic instructions Stop and Deceleration Stop will be received even while operating with move instructions (Peak Keep Time may be inserted into the Deceleration Stop instruction with the triangular drive prevention function).

In contrast, move instructions will be received only while stopped. While logical position coordinates are transitioning, move instructions will not be received since the initial position for movement can hardly be identified. If the user application mistakenly issues a move instruction during operation, MKY44-MC01A will return an error saying that it will not receive the instruction.

1.3.5 Operation of Move Instructions to Maintain Constant Speed

Among the move instructions, the following four instructions move with constant speed.

1. Distance specification lower speed movement (DS_LFlat)
2. Distance specification upper speed movement (DS_UFlat)
3. Target specification lower speed movement (TS_LFlat)
4. Target specification upper speed movement (TS_UFlat)

The part corresponding to the graphical area of these speed transitions is the distance. For example, the movement time required for a “distance specification lower speed movement (DS_LFlat)” instruction when the

lower speed is “1,000 pps” and the relative distance is “10,000” is “10 seconds” [10,000 ÷ 1,000]. The movement time required for a “distance specification upper speed movement (DS_UFlat)” instruction when the upper speed is “5,000 pps” and the relative distance is “10,000” is “2 seconds”. The distance in both cases is “10,000” and the area of the diagram is also the same. Also, the distance matches the pulse count output by the pulse output pin of MKY44-MC01A (see Figure 1.12).

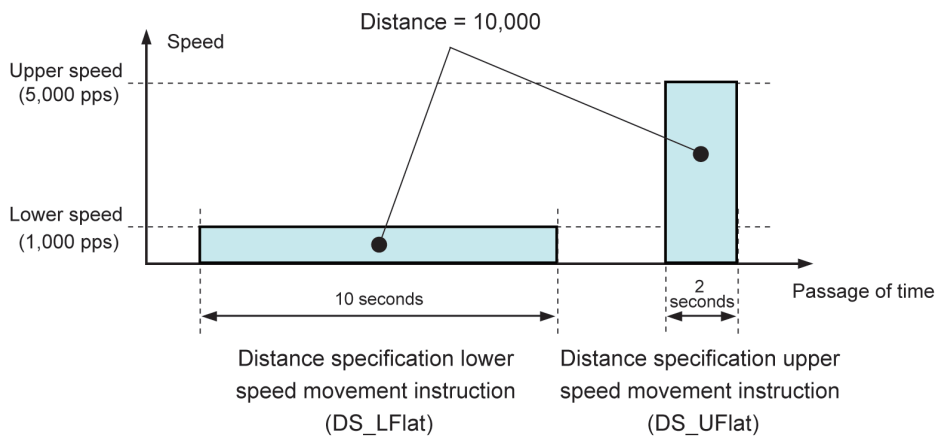

Fig. 1.12 Move Instructions to Maintain Constant Speed

1.3.6 Trapezoidal Speed Control and Pattern

Among the move instructions, the following two instructions execute “trapezoidal speed control” for acceleration from the lower speed to the upper speed, a period at the upper speed, and then deceleration to the lower speed and stop (see Figure 1.13).

1. Distance specification pattern movement (DS_Pattern)
2. Target specification pattern movement (TS_Pattern)

Most stepping motors cannot start from upper speed rotation because of structural features. Therefore, it is common to use “trapezoidal speed control” for driving a stepping motor.

The part corresponding to the graphical area of “trapezoidal speed control” in a pattern move instruction is the distance. This distance matches the pulse count output by the pulse output pin of MKY44-MC01A.

Trapezoidal speed control comes into effect when the target position coordinates or the parameters of distance, lower speed, upper speed, and acceleration (plus and minus acceleration) are all available. With MKY44-MC01A, a set of these parameters, or the figure of speed transition formed by a set of parameters, is called a “pattern”.

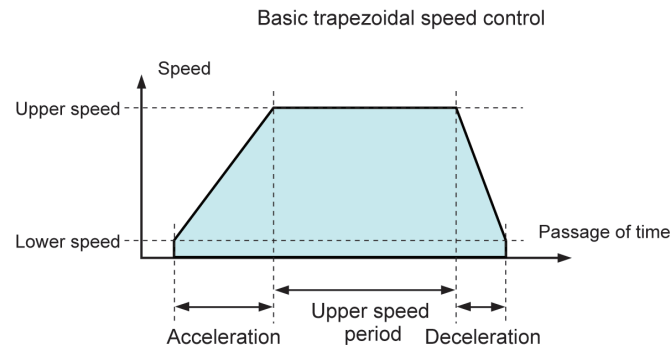

Fig. 1.13 Trapezoidal Speed Control

1.3.7 Relationship of Patterns

In basic trapezoidal speed control (see Figure 1.14 A), conceptually, there is no rules for the time to maintain the upper speed. Therefore, the minimum distance forming the trapezoid is an area where the time of the upper speed period is “0” (see Figure 1.14 B). Although this is no longer a trapezoid but intentional triangular drive, MKY44-MC01A can execute pattern move instructions specifying the distance not less than this area.

For example, the theoretical value of distance required for pattern formation is $((500 + 4,500) \times 4) \div 2 + ((500 + 4,500) \times 2) \div 2 = “15,000”$ according to the calculation method of the graphical area when it is set that lower speed is “500 pps”, upper speed is “4,500 pps”, plus acceleration is “1,000 pps/sec (10 pps/10 ms)”, and minus acceleration is “2,000 pps/sec (20 pps/10 ms)”.

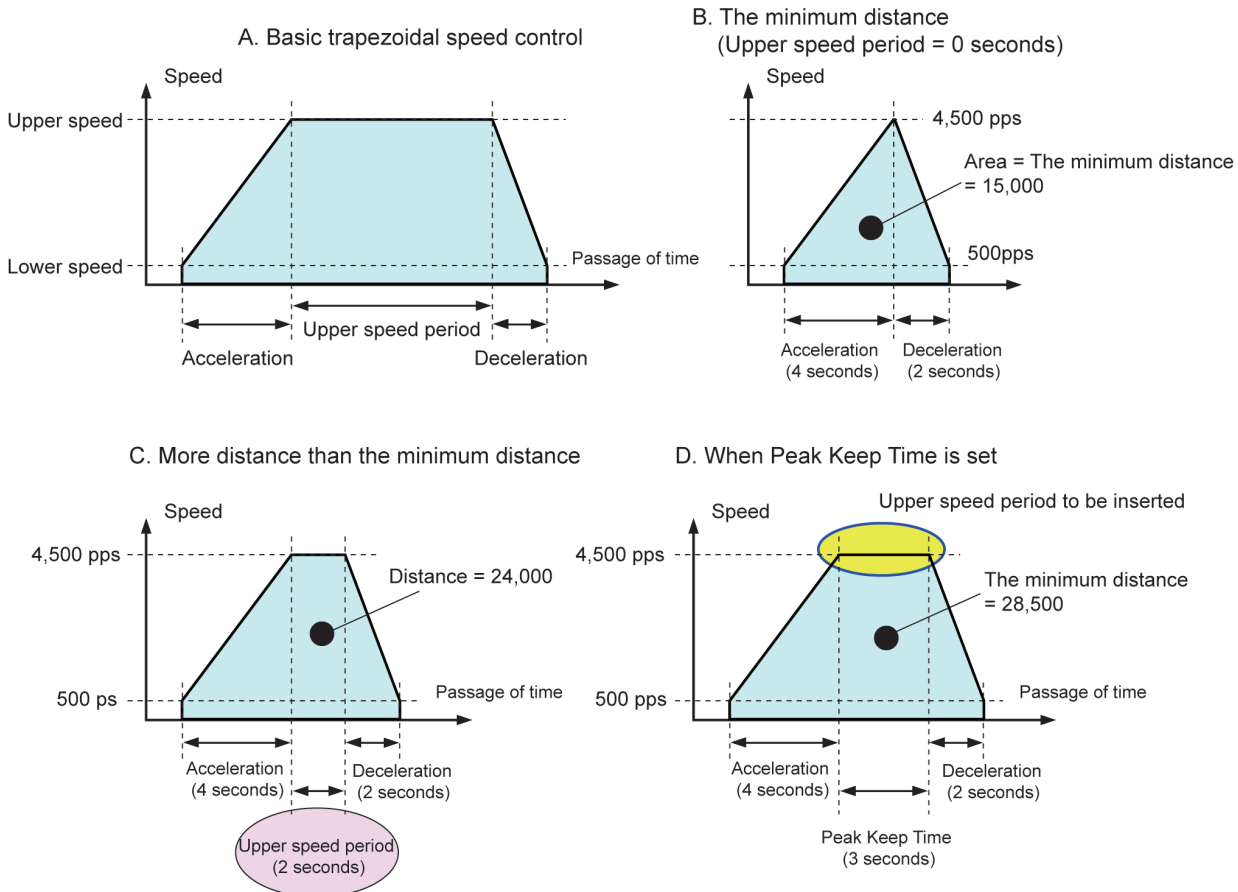

Fig. 1.14 Relationships between Distance and Patterns

If the distance of “24,000”, which is more than the minimum distance forming the trapezoid, is commanded in this pattern, a trapezoidal speed control where upper speed period of 2 seconds is inserted will be performed (see Figure 1.14 C). If a distance less than the minimum distance to form the trapezoid (less than “15,000” in this example) is instructed, MKY44-MC01A will return an error saying that the distance is not enough to form the pattern.

If a value other than “0” is set for Peak Keep Time in order to enable the triangular drive prevention function, the distance required for pattern formation will be increased by the distance that has Peak Keep Time as upper speed period. In the example shown in Figure 1.14 D, where “3 seconds” is set for Peak Keep Time, the minimum distance forming the trapezoid is “28,500”.

 **Reference**

The values such as “15,000” and “28,500” described above are theoretical values. The values that become errors are less than “15,019” and “28,520” with up to 0.2% calculation error.

1.3.8 Pattern Reduction Function

Most applications using stepping motors try to avoid calculation of the minimum distance and errors caused when they fall below it, except when controlling motor precisely and sensitively. If the lower speed, acceleration rate, and distance (coordinates) are maintained, it is preferred not to return errors but to operate accurately to some extent.

MKY44-MC01A has an optional function that operates reasonably adjusting the patterns without returning errors when it receives pattern move instructions with less distance than the distance required for pattern formation. This function is called “Pattern Reduction” function.

The pattern reduction function of MKY44-MC01A is not an equal ratio reduction of geometric graphics. It adjusts the upper speed and upper speed period while maintaining the parameter values of lower speed and acceleration

Figure 1.15 shows the reduction examples when the distance required for pattern formation is set to 80%, 60%, 40%, 20%, 10%, and 5%. The pattern reduction function can be used regardless of the type of speed curve, the difference between acceleration rate and deceleration rate, and enabling/disabling of the triangular drive prevention function.

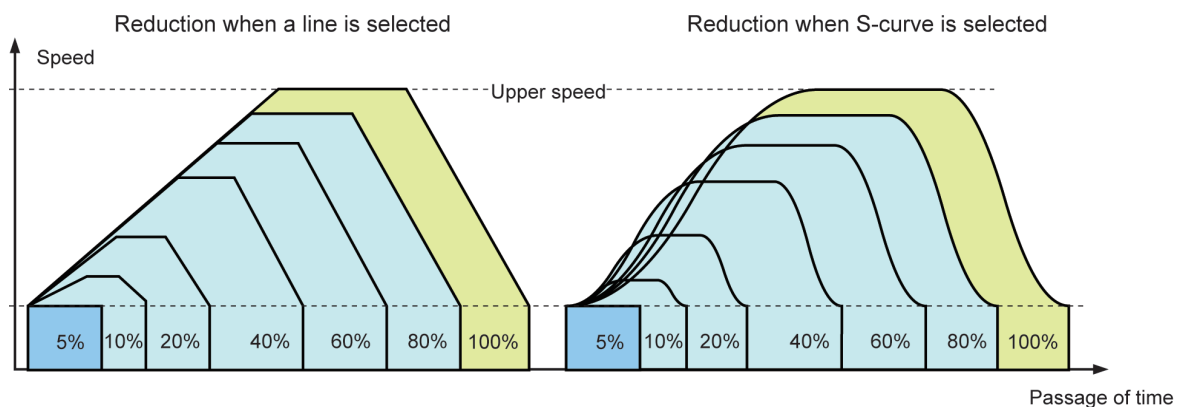

Fig. 1.15 Pattern Reduction

If either of the following two reasons apply, the pattern reduction function of MKY44-MC01A will conclude that the formation of trapezoidal speed control is inappropriate and perform the movement at the lower speed without speed transition. This is only when the reduction rate becomes very high with little distance. “5%” in Figure 1.15 is an example of this case.

- (1) When the speed transition width of lower speed and upper speed is less than 32 pps
- (2) When the required time for acceleration or deceleration is less than or equal to 8 ms

Turn ON/OFF the pattern reduction function using the PRE (Pattern Reduction Enable) bit of the PG2 (Property Group 2) register.



“ON” is selected for the pattern reduction function in the factory default setting.

1.3.9 Usage Specifying Only Distance

Auto Start Enable (ASE) function is one of the optional settings for MKY44-MC01A.

If this function is selected and the user application sets “relative distance” or “absolute distance”, the “distance specification pattern movement (DS_Pattern)” instruction will be started simultaneously. Similarly, if the user application sets “target position coordinate”, “target specification pattern movement (TS_Pattern)” will be started simultaneously (see Table 1-9).

Table 1-9 Auto Start Enable Function

Parameter that triggers instruction execution			Instruction starting automatically	
Relative distance	Absolute distance	Target position coordinate	Instruction	Name
○	---	---	Distance specification pattern movement	DS_Pattern
---	○	---		
---	---	○	Target specification pattern movement	TS_Pattern

An error will occur if this auto start enable option is selected and the speed parameter is inappropriate. By turning on the parameter auto correction function, one can often avoid errors. For the details of the parameter auto correction function, see **“1.2.5 Parameter Auto Correction Function”**.

If the most high-performance parameter available in the application environment is set and all the options of auto start enable function, pattern reduction function, and parameter auto correction function are enabled, the user application can easily control the motion by just setting the distance or the target position coordinate parameters.

Set the auto start enable function using the ASE (Auto Start Enable) bit of the PG2 (Property Group 2) register.



In the factory default setting, the pattern reduction function is ON, the parameter auto correction function is ON, and the auto start enable function is OFF.

1.4 Origin Detection

This section describes origin detection.

Since the application for controlling distance controls using logical coordinates, the logical coordinate itself requires some sort of control point. In most applications using stepping motors, an origin sensor is set up and the position detected by the sensor is set as a control point where the value of logical coordinate is "0".

1.4.1 Origin Search Instruction and Speed Transition

MKY44-MC01A has an origin search instruction. This instruction causes movement for the absolute distance of [current logical coordinate position + (lower speed ÷ 2)] from the current logical coordinate position to the direction of logical coordinate "0". The origin search instruction causes movement according to the current parameters of upper speed, lower speed, plus acceleration, minus acceleration, acceleration/deceleration curve selection, and triangular drive prevention function.

Only the origin search instruction can make the pattern reduction function work even if the pattern reduction function option is OFF. Similarly, only the origin search instruction can make the parameter auto correction function work even if parameter auto correction function option is OFF. This can reduce burdens such as sensitive attention to parameters when issuing origin search instructions.

The origin search instruction causes movement for the absolute distance of [current logical coordinate position - (lower speed ÷ 2)] with speed transition just like a pattern move instruction. After decelerating to the lower speed, it will stop after traveling at the lower speed the same absolute distance as the value of lower speed. According to this speed transition, a pattern that moves while maintaining the lower speed for 0.5 seconds before and after logical coordinate "0" will be formed (see Figure 1.16). If the distance between the current logical coordinate position and "0" is smaller than the value of [lower speed ÷ 2], it will move to the opposite position [lower speed ÷ 2] at the lower speed.

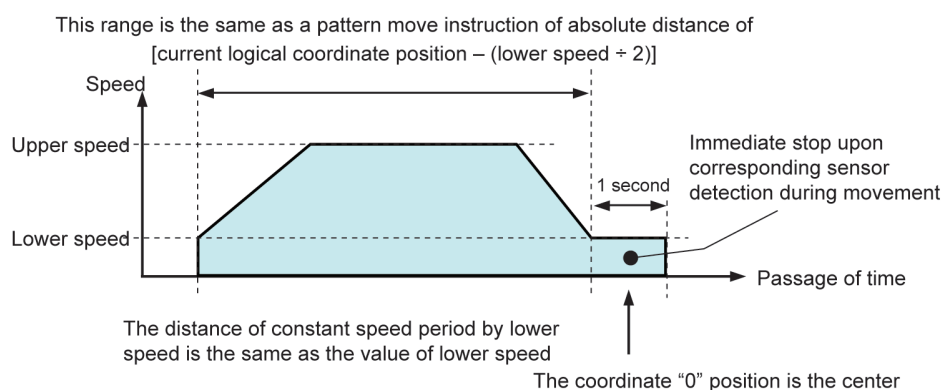

Fig. 1.16 Speed Transition of Origin Search



Reference

The movement for origin search can be intentionally set to a constant speed from beginning to end. In order to do this, set the difference between the parameter values of upper speed and lower speed "31" or less. This causes movement at the constant lower speed without performing speed transition by trapezoidal speed control.

1.4.2 Three Origin Search Instructions and Their Detection Sensors

MKY44-MC01A has three origin search instructions. Although the move methods of these instructions are all the same, the target sensor and detecting method are different. These three origin search instructions immediately stop if the target sensor is detected while moving (see Table 1-10).

Table 1-10 Origin Search Instructions and Target Sensors

Instruction	Name	Target for detection	
		Sensor	Status
Origin Search 1	OriginSearch1	Origin Sensor	OFF ⇒ ON
Origin Search 2	OriginSearch2		ON ⇒ OFF
Origin Search 3	OriginSearch3	EZ sensor (Di0)	OFF ⇒ ON

Movement by the Origin Search 1 (OriginSearch1) instruction immediately stops when the origin sensor transitions from OFF status to ON status (see Figure 1.17). Therefore, if the origin sensor is ON when this instruction is received, it will say so with an error.

Movement by the Origin Search 2 (OriginSearch2) instruction immediately stops when the origin sensor transitions from ON status to OFF status (see Figure 1.18). This instruction starts operation regardless of the origin sensor status at the point of receiving the instruction.

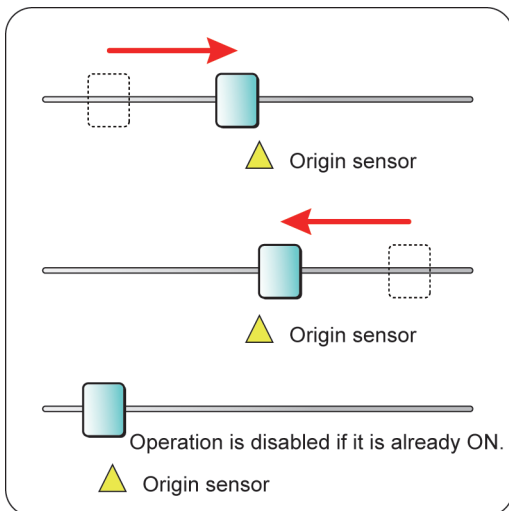

Fig. 1.17 Stop by Detecting the Sensor of Origin Search 1

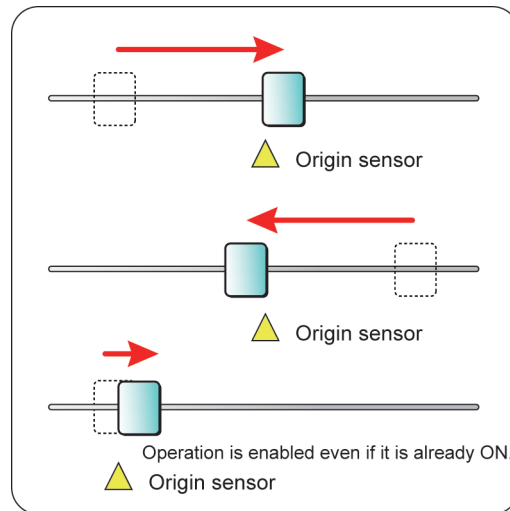

Fig. 1.18 Stop by Detecting the Sensor of Origin Search 2

Movement by the Origin Search 3 (OriginSearch3) instruction immediately stops when the EZ (Encoder Zero) sensor transitions from OFF status to ON status. Therefore, if the EZ sensor is ON when this instruction is received, it will say so with an error and will not operate. The input pin of the EZ sensor is shared with the general-purpose input pin Di0. MKY44-MC01A recognizes the input of the Di0 pin as the EZ sensor only when the Origin Search 3 instruction is executed. Thus, the EZ sensor should be connected to the Di0 pin for user applications using the EZ sensor.

1.4.3 Usage Example of the Origin Search Instruction and Initialization of Logical Coordinate Value

Figure 1.19 shows an example using the Origin Search 2 instruction and the Origin Search 3 instruction. In this example, it is assumed that the mechanism of the device is adjusted to issue an EZ (Encoder Zero) sensor signal when the center of the slide table matches the position of the origin sensor. In Figure 1.19, first, with the Origin Search 2 instruction, the slide table going through S-curve speed transition is stopped by the origin sensor right after the table passes the sensor. Then, the Origin Search 3 instruction matches the center position of the slide table with the position of the origin sensor and stops the table.

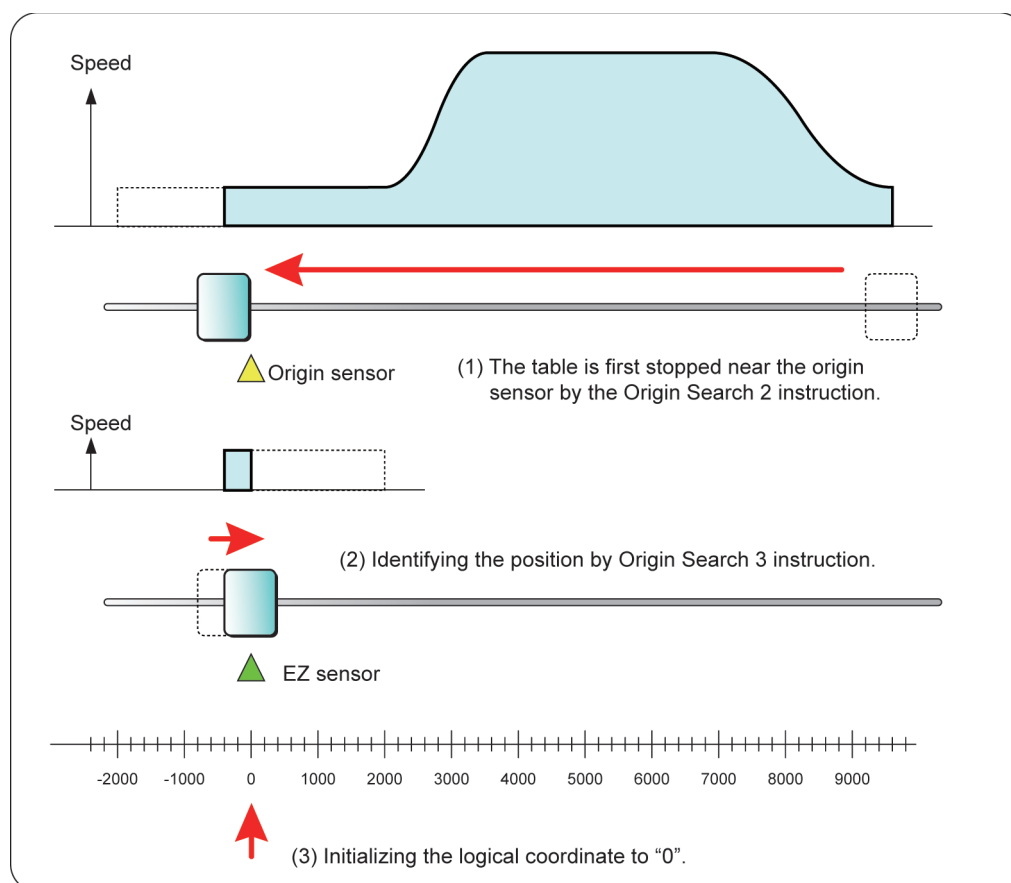

Fig. 1.19 Usage Example of Origin Search Instruction

The logical coordinate of MKY44-MC01A can be initialized to an arbitrary value. Since the origin search instruction of MKY44-MC01A operates to target logical coordinate “0”, it is normally recommended to initialize the logical coordinate to “0” in the position where the table is stopped by the origin sensor and EZ (Encoder Zero) sensor as in Figure 1.19.

Also, in MKY44-MC01A, the internal logical coordinate will be initialized to “0” after going through the reset state due to power on/off etc. In some user applications, it is possible to execute origin search to determine the proper logical coordinate “0” after temporarily setting the logical coordinate to a certain value.



After MKY44-MC01A goes through the reset state, the logical coordinate inside MKY44-MC01A may not match the coordinate of the user equipment. In the effort to align the logical coordinate inside MKY44-MC01A and the coordinate of user equipment, if the origin search instruction is used without knowing the coordinate of user equipment, the direction to start operation or the distance may become inappropriate. Make sure you understand the operation of the origin search instruction, and execute operation using proper procedure to match the application.

1.5 Stop Functions

This section describes various stop functions.

MKY44-MC01A has various stop functions including the function to stop when a signal is input externally and the function to stop when there is a problem with the network, as well as stop instructions and deceleration stop instructions (see Figure 1.20). Some of these functions stops by stop types (selecting immediate stop or deceleration stop) that can be set for each axis.

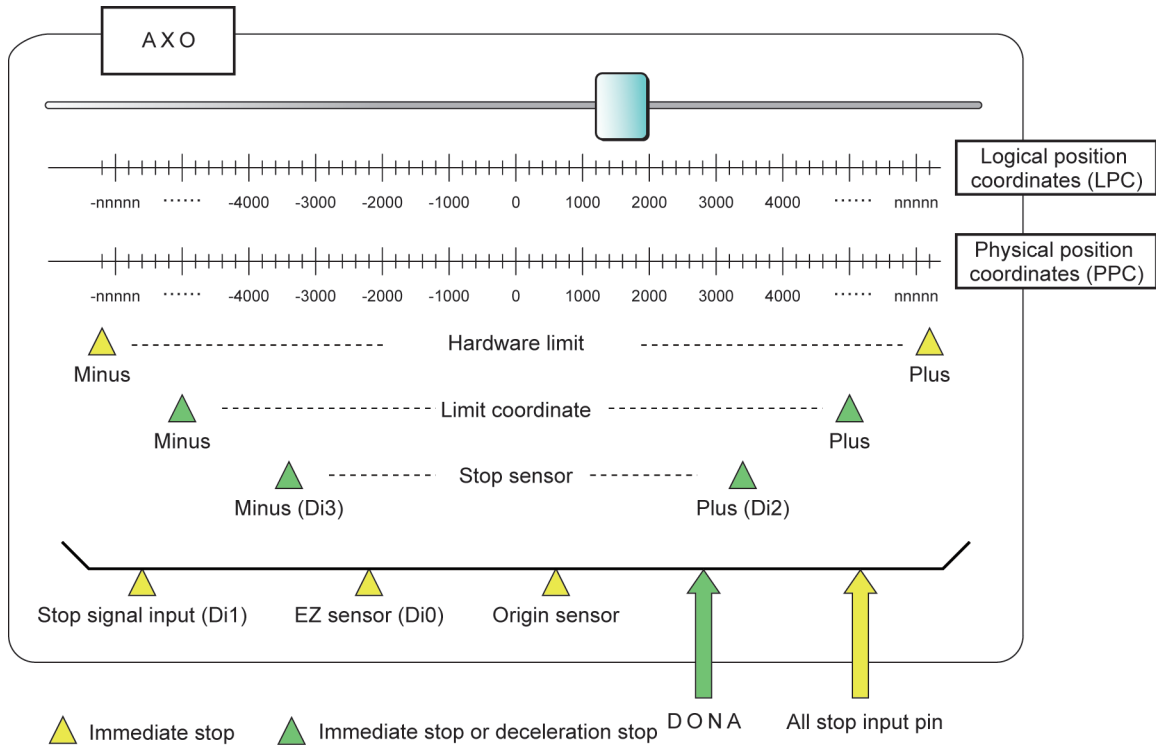

Fig. 1.20 Sensors and Signals of Stop System

If an operation start instructions received when it should stop because stop function is enabled, an error saying that it will not receive instructions will occur. Table 1-11 shows the factory default setting of various stop functions. Set stop types and enabling/disabling of stop functions using the STS (Stop Type Select) bit of the PG2 (Property Group 2) register.

Table 1-11 Factory Default Setting of Stop Functions

All stop	DONA stop	Hardware limit	Stop signal input (Di1)	Limit coordinate	Stop sensor (Di2, Di3)	Origin sensor	EZ sensor
⊙ Immediate stop	○ Deceleration stop	⊙ Immediate stop	× Immediate stop	○ Target LPC deceleration stop	× Deceleration stop	△ Immediate stop	△ Immediate stop

⊙: Always enabled (no setting)

○: Set as enabled

△: Depending on the instruction

×: Set as disabled

1.5.1 All Stop

If the all stop input pin transitions to be active while the axis is operating, it will immediately stop regardless of operating direction and coordinate position. If an operation start instructions received when the state of this pin is active, an error saying that it will not receive instructions will occur.

1.5.2 DONA Stop

If there is no source to issue an operation instruction to MKY44-MC01A (Do Not Arrival state of CUnet), a function to stop the operating axis can be selected using the DONAS (DONA Stop) bit of the PG2 (Property Group 2) register. Such a stop is called a “DONA (DO Not Arrival) stop”. This stop style is executed using stop styles set in the STS (Stop Type Select) bit of the PG2 register. However, during distance specification upper speed movement (DS_UFlat) or target specification upper speed movement (TS_UFlat), it stops immediately even if deceleration stop is selected in the STS bit. This DONA stop function can improve the security and reliability of the system. For details on DONA, see “**1.9.6 Addressing DONA and Network Failure**”.

1.5.3 Stop Using Origin Sensor, EZ Sensor, and Stop Signal Input

The origin sensor is enabled when “Origin Search Instruction 1” or “Origin Search Instruction 2” is executed. The EZ (Encoder Zero) sensor is enabled when “Origin Search Instruction 3” is executed. For details, see “**1.4 Origin Detection**”.

Stop signal input is enabled when the option to use the general-purpose input pin Di1 as the stop signal input pin is selected in the Di1FS (Di1 Function Select) bit of the PG2 register. If stop signal input transitions to be active while the axis is operating, it will immediately stop regardless of the operating direction and coordinate position.

1.5.4 Stop Using Stop Sensors and Hardware Limits

MKY44-MC01A has plus and minus hardware limit input pins for each axis. These input pins are always enabled.

The stop sensors are enabled when the option to use the general-purpose input pins Di2 and Di3 as the input pins to connect the stop sensors is selected in the Di23FS (Di2,3 Function Select) bit of the PG2 register.

The stop sensors and hardware limits function if the plus side transitions to be active while an axis is operating towards the positive direction or if the minus side transitions to be active while an axis is operating towards the negative direction. When a stop sensor functions, it will stop, using the stop style set in the STS (Stop Type Select) bit of the PG2 register. When a hardware limit functions, it will immediately stop.



Reference

In the factory default setting, the DONA (DO Not Arrival) stop function is ON. Since the Di1 pin is set for general-purpose input, stop signal input is disabled. Since the Di2 and Di3 pins are also set for general-purpose input, these two stop sensors are disabled.

1.5.5 Physical Position Coordinate

MKY44-MC01A has a signed 24-bit up/down counter, which can receive signals from encoders and generate position coordinates (see Figure 1.21). The value of this counter is called “Physical Position Coordinates (PPC)”. The coordinate values handled by “Physical Position Coordinates (PPC)” are “-8,388,608 to 8,388,607 (0x800000 to 0x7FFFFF)”.

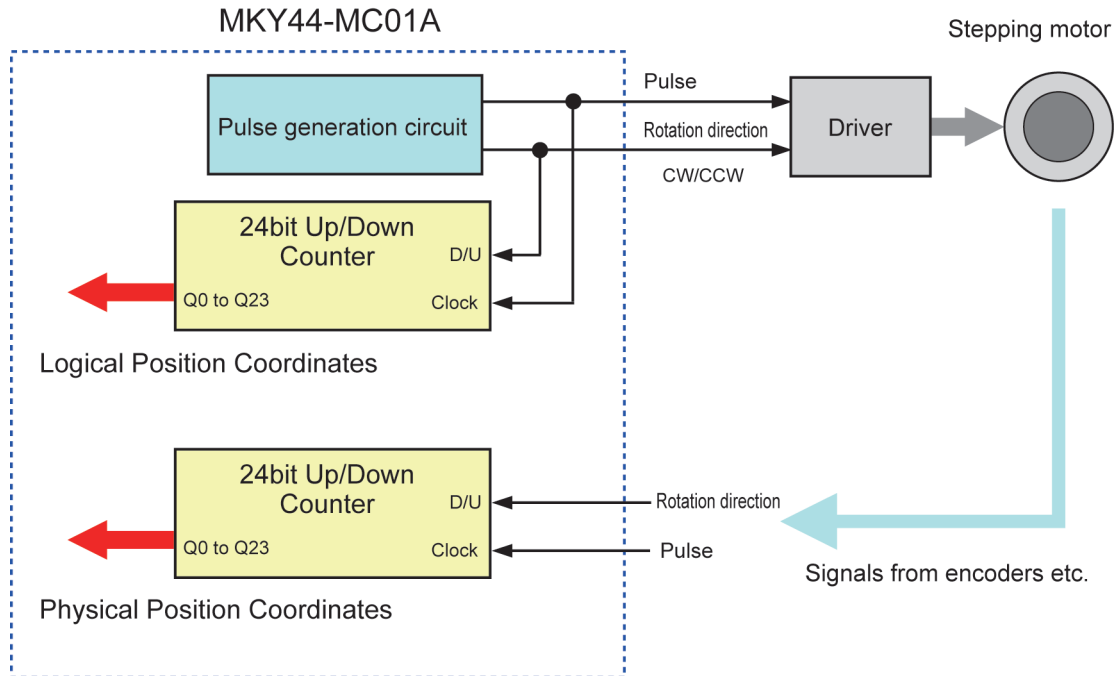

Fig. 1.21 Up/Down Counter Comprising Physical Position Coordinates

1.5.6 Stop Setting Using Limit Coordinates

MKY44-MC01A has a register to set limit coordinates for both the plus and the minus sides. If the coordinate becomes greater than or equal to the limit coordinate of plus side while the axis is operating towards the positive direction, the stop by the limit coordinate of the plus side will function. Similarly, if the coordinate becomes less than or equal to the limit coordinate of the minus side while the axis is operating towards the negative direction, the stop by the limit coordinate of the minus side will function.

Enabling/disabling of stop using limit coordinates can be set using the LCE (Limit Coordinates Enable) bit of the PG2 (Property Group 2) register. Also, using the LCLPPP (Limit Coordinates LP/PP) bit of the PG2 register, you can set whether to compare limit coordinates with “Logical Position Coordinates (LPC)” or “Physical Position Coordinates (PPC)”.

If stop using limit coordinates is enabled and an operation start instructions received when a limit coordinate has been exceeded, an error saying that it will not receive instructions will occur.

 **Reference**

In the factory default setting, stop using limit coordinates is enabled, and Logical Position Coordinates (LPC) is set to be compared with limit coordinates. Even if immediate stop is selected, the stop position may slightly exceed the limit coordinate because of the distance and the speed.

1.6 Pattern Memory and File

MKY44-MC01A has static RAM inside. The following set of parameters that comprise a pattern can be saved in this static RAM for up to 32 memories.

- (1) Target position coordinate
- (2) Distance
- (3) Lower speed
- (4) Upper speed
- (5) Acceleration (plus acceleration and minus acceleration)

For MKY44-MC01A, this memory is called “pattern memory”. Pattern memories are numbered as “0 to 31 (0x00 to 0x1F)”. Using these numbers, a set of parameters can be read and the contents can be updated.

MKY44-MC01A also has flash ROM. Only when the axis is stopped, pattern memory can be saved in flash ROM as one file by giving instructions to MKY44-MC01A (see Figure 1.22).

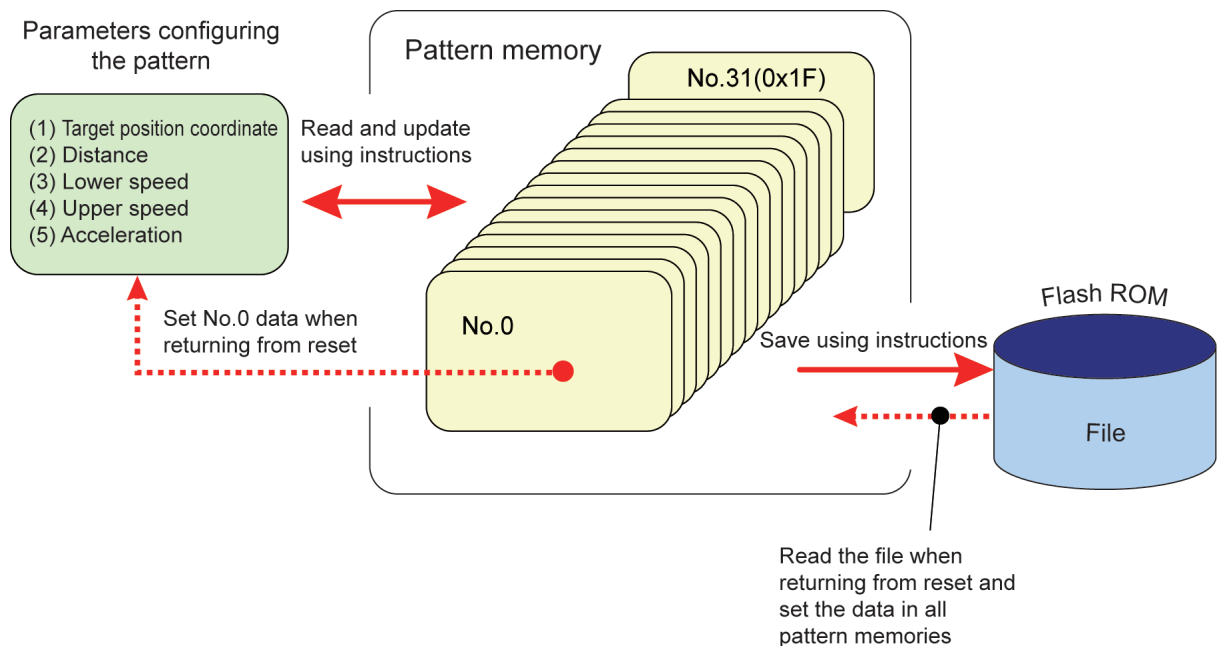

Fig. 1.22 Pattern Memory

The file saved in flash ROM will not be lost when the power of MKY44-MC01A is OFF. After the power is turned on and MKY44-MC01A returns from the reset state, it will read the file in flash ROM and set the data in all pattern memories. Then, the data of the number 0 pattern memory will be set to the parameters comprising the pattern.

1.7 Synchronization of Operation Instructions

This section describes synchronization of operation instructions.

The execution start of MKY44-MC01A's basic instructions and move instructions except for the origin detection can be synchronized with other MKY44-MCxx products. If MKY44-MC01A receives a ready instruction for synchronization, the SR (Synchronization Ready) flag will transition to "1" and it will wait for instruction execution. If a synchronization trigger is issued at this state, the instruction will be executed.

Figure 1.23 shows an example in which the timing of executing instructions is synchronized using three MKY44-MC01As. The synchronization trigger of (4) synchronizes three axes and the trigger of (7) synchronizes two axes. In the figure, the first axis of MKY44-MC01A is described as "AX0", the second axis is described as "AX1", and the third axis is described as "AX2".

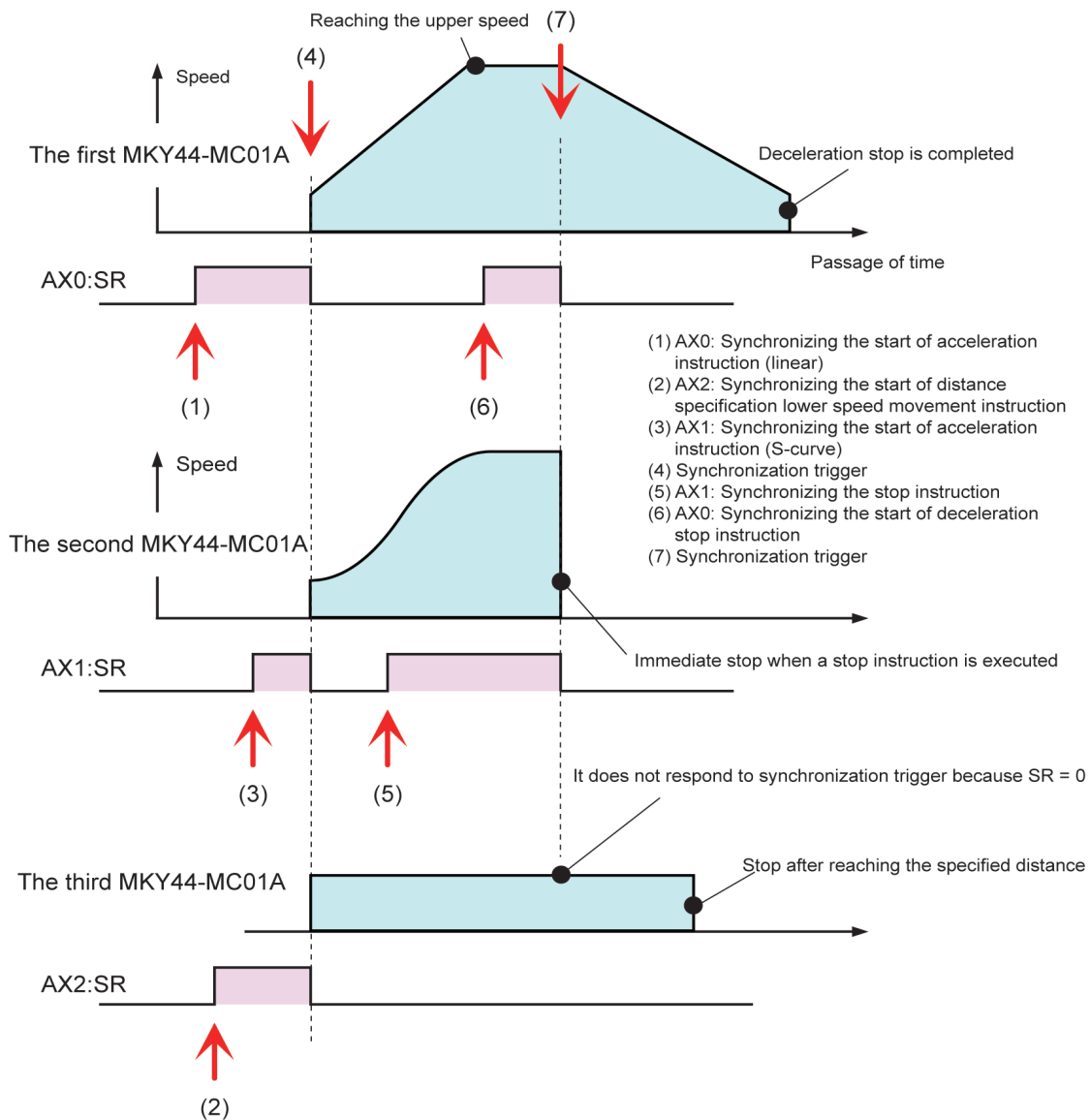

Fig. 1.23 Example of Operation Instruction



The synchronization in MKY44-MC01A is to synchronize the execution start of instructions. It is not designed to provide interpolation function that synchronizes the timing of operation progress and result.

1.7.1 Synchronization Trigger

The synchronization triggers include “external signal synchronization” using signals to input to the synchronization input pin and “shared data synchronization” using data in the shared memory of CUnet. MKY44-MC01A cannot use both synchronization triggers at the same time. Set which synchronization trigger to use by using the SyncT (Sync Type) bit of the PG2 (Property Group 2) register.

In “shared data synchronization”, you can set the address and data of trigger conditions. “Shared data synchronization” provides a synchronization trigger when the address data set as the trigger condition newly matches the set data. For both synchronizations, signals with transition interval of at least 2 ms are required for a synchronization trigger.

The operation instructions of the synchronization trigger can synchronize with other MKY44-MCxx products connected to CUnet. To use “external signal synchronization” for this purpose, a hardware signal commonly connected to the device of each axis is required. To use “shared data synchronization”, a hardware signal commonly connected to the device of each axis is not required. Also, if “shared data synchronization” is used, you can group the devices to synchronize. Specifically, synchronization of each group is enabled by grouping each axis in advance and setting different trigger conditions of “shared data synchronization” for each group in a system in which multiple MKY44-MC01As are connected to CUnet.



Reference

In the factory default setting, shared data synchronization is selected.

1.7.2 Synchronous Performance

The synchronous performance with other MKY44-MCxx products connected to CUnet is within 2 ms regardless of the operation to be executed. There is no difference in the synchronous performance of “external signal synchronization” and “shared data synchronization” (see Table 1-12).

Table 1-12 Synchronization Performance

Target for synchronization	Synchronous performance
Each axis of other MKY44-MCxx products	Within 2 ms



Caution

The synchronous performance of “shared data synchronization” with other MKY44-MCxx products connected to CUnet refers to the time value inside MKY44-MC01A. User applications may need to add time to propagate data on the network, cycle time for CUnet, or time related to network failure.

1.7.3 Releasing Synchronization Wait State

The state of MKY44-MC01A waiting for a synchronization trigger is released when instructions other than the ready instruction of synchronization or manual operation are given. When the wait state is released, the SR (Synchronization Ready) flag returns to “0”.

1.8 Addressing Manual Operation

This section describes addressing manual operation.

The rotation direction and pulse signals output by MKY44-MC01A can be also operated manually. The input pins for manual operation are shared with the Di2 and Di3 pins for general-purpose input and stop sensor input. To perform manual operation, set the option to use the Di2 and Di3 pins as manual operation input using the Di23FS bit (Di2,3 Function Select) bit of the PG2 (Property Group 2) register.

To the Di2 pin, connect the manual signal that enables rotation in the positive direction. To the Di3 pin, connect the manual signal that enables rotation in the negative direction. MKY44-MC01A does not receive manual operation when both the Di2 pin and the Di3 pin are active.

When starting operation with manual operation, operation will not start if there are already stop factors such as having the hardware limit ON. In such a case, an error will not be given to the user application, because the user application is involved with MKY44-MC01A.



Reference

In the factory setting, the Di2 pin and Di3 pin are selected as general-purpose input so that manual operation cannot be received.

For the stop factors in the case that operation cannot be started manually, see **“1.5 Stop Functions”**.

1.8.1 Continue Mode and Single Mode

For manual operation, you can select from “Continue Mode”, in which pulses are output continuously while the manual signal is active, and “Single Mode”, in which pulses of fixed distance are output in each time the manual signal transitions to be active (see Figure 1.24).

Make these selections by Di23FS (Di2, 3 Function Select) bit of PG2 register.

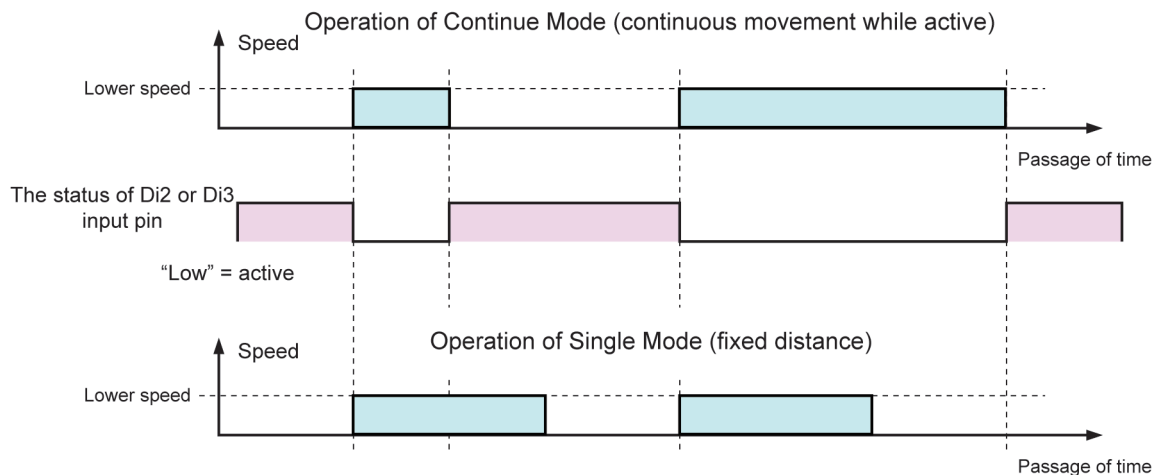

Fig. 1.24 Continue Mode and Single Mode

1.8.2 Speed and Distance in Manual Operation

The pulse signal speed output by MKY44-MC01A in manual operation is the lower speed registered in number “31 (0x1F)” of the pattern memory. The distance (pulse count) output by MKY44-MC01A in “Single Mode” is also the distance registered in number “31” of the pattern memory. In user applications using manual operation, it is recommended to set in advance and register the lower speed and the distance in number “31” of the pattern memory (see Table 1-13).

Table 1-13 Addressing Manual Operation

Manual mode	Operation	Speed	Distance
Continue	Continue to move while manual signal is active	Lower speed registered in number “31” of the pattern memory	---
Single	Start moving a fixed distance when manual signal transitions to be active		The distance registered in number “31” of the pattern memory. However, it must be less than or equal to the upper speed value.

If a large value is mistakenly registered as the distance in number “31” of the pattern memory, there may be undesirable effects. For instance, a manual signal may continue to operate for a very long time after the manual signal transitions to be active. Therefore, to prevent this, if the distance in number “31” of the pattern memory exceeds the value set for the upper speed in MKY44-MC01A, manual operation will not start. Thus, the maximum value of the distance that can be set for Single Mode is within the value of upper speed.

Addressing manual operation with MKY44-MC01A is suitable when manual adjustment is required for the device using MKY44-MC01A. MKY44-MC01A’s Single Mode is also suitable as the controller of a dispenser device such as needs a fixed distance or ejection triggered by an external input signal.



Reference

The following is the content registered in number “31” of the pattern memory in the factory default setting.
Target position coordinate = 0, relative distance = 2,000, lower speed = 2,000 pps, upper speed = 2,500 pps

1.9 Utility Functions

This section describes the utility functions for motion control provided by MKY44-MC01A.

1.9.1 Remote Reset from Applications

User applications can execute a hardware reset on MKY44-MC01A by performing exceptional operations to the network. For how to execute this, see **“2.6 Exceptional Operation”**.



Use remote reset of MKY44-MC01A only when user application requires it such as when initializing the system.

1.9.2 General-Purpose Input Pins/General-Purpose Output Pins

MKY44-MC01A has four general-purpose input pins for axis control, #Di0 to #Di3, and four general-purpose output pins for axis control, Do0 to Do3. Some of these pins are shared with other functions as shown in Table 1-14. Select the function of shared pins by setting the Di1FS (Di1 Function Select) bit, Di23FS (Di2,3 Function Select) bit, and Do2FS (Do2 Function Select) bit of the PG2 (Property Group 2) register. The factory default settings are general-purpose input and general-purpose output.

Table 1-14 General-Purpose I/O Pins and Convertible Functions

Pin	Function 1	Function 2	Function 3
#Di0	General-purpose input	EZ (Encoder Zero) sensor	---
#Di1		Stop signal input	---
#Di2		Plus stop sensor	Manual positive direction SW
#Di3		Minus stop sensor	Manual negative direction SW
Do0	General-purpose output	---	---
Do1		---	---
Do2		Axis operation signal	---
Do3		Watchdog timer output	---

MKY44-MC01A has general-purpose input ports without convertible functions (#Di20 to #Di23 pins) and general-purpose output ports without convertible functions (Do20 to Do23 pins). These are called “port 2”. The control of Port 2 is performed by the P2C (Port 2 Control) register.

1.9.3 Output Signal Indicating Axis Operating

An “axis operating signal” can be output to the general-purpose output pin Do2. The signal shows “0” when the axis is stopped and “1” when it is operating. To use this function, set the Do2FS (Do2 Function Select) bit of the PG2 register. The pulse output signal will not transition in the 10 μ s before and after transition of this signal. If “axis operating signal” is selected, the Do2 bit data of 4-bit data that is output to the general-purpose Do pin will not be written to the Do2 pin.

**Reference**

The factory default setting of the axis operating signal output option is OFF.

1.9.4 Do3 Watchdog Timer Function

Some user applications may continue to supply electric current (maintain excitation) to a stopped stepping motor. If it is neglected like this for a long time, the motor can be overheated unnecessarily. In such a case, it may be useful if there is a signal that transitions to OFF after a certain period of time from when the motor is stopped. MKY44-MC01A has a “Do3 watchdog timer function” that can be used for such purposes. The general-purpose output pin Do3 is the target of this function.

A time value is set for the Do3 watchdog timer function. If the time value is set to “0”, the Do3 pin will function as a normal general-purpose Do pin. If the time value is set to other than “0”, “1” is set to the Do3 pin. Then, when the axis is in the stopped state for a time that reaches the set value, the Do3 pin will transition to “0”. If the axis operates while the watchdog timer is in progress, the timer will be initialized. When the Do3 watchdog timer is being used, there is write protection even if “0” is written to the Do3 pin bit while the axis is operating. When the axis is stopped, “0” can be written.

The numerical values that can be set for the Do3 watchdog timer are “0 to 255 (0xFF)”. “1” in these values means “2.55 seconds”. Therefore, the time that can be set for the Do3 watchdog timer is “0 to 650.25 seconds (approximately 10 minutes and 50 seconds)”.

The output signal of the Do3 pin can be connected to the excitation ON/OFF input pin of driver devices or the current control High/Low input pin. Choose the connection suitable for the user application.

MKY44-MC01A also has a function that returns an error when it receives an operation start instruction when the Do3 pin is “0”. This function adds the axis start condition that the Do3 pin should be “1”. To enable or disable this function, set the SCD03 (Start Condition with Do3) bit of the PG2 (Property Group 2) register.

**Reference**

In the factory default setting, “0” is set for Do3 watchdog timer value. Therefore, the Do3 pin functions as a simple general-purpose Do pin. Also, the option adding the start condition that Do3 pin should be “1” is OFF.

1.9.5 Logical Inversion Function for Pins

Generally, the clockwise direction from an anterior view is the positive rotation direction, and the counterclockwise direction is the negative direction. However, in user applications in which a motor is installed from the back, you may want to reverse the rotation direction. To address such needs, MKY44-MC01A can invert the signal logic of each of the pins shown in Table 1-15.

These signal inversions can be set by the InvDo012 (Invert Do012) bit, InvDo3 (Invert Do3) bit, InvMD (Invert Motion Direction) bit, and InvPPD (Invert Physical Pulse Direction) bit of the PG2 (Property Group 2) register.

The #Di20 to #Di23 and Do20 to Do23 pins of general-purpose I/O Port 2, without convertible function, can set logical inversion for each bit using the P2I (Port 2 Invert) register as shown in Table 1-15.

Table 1-15 Pins Settable for Logical Inversion

I/O	Pin	Target function 1	Target function 2	Remark
Output	Do0	General-purpose output	---	Do0, Do1, and Do2 are set for logical inversion together.
	Do1			
	Do2	Axis operating signal output		
	Do3	General-purpose output	Watchdog timer output	---
	DIR	Motor rotation direction	---	---
Input	PPCDIR	Physical coordinate Up/Down	---	---
Output	Do20	General-purpose output	---	Corresponding to bits OP210 to OP213 of the P2I register
	Do21			
	Do22			
	Do23			
Input	#Di20	General-purpose input	---	Corresponding to bits IP210 to IP213 of the P2I register
	#Di21			
	#Di22			
	#Di23			



Reference

In the factory default setting, the signal inversions options are all OFF (non-inverted).

1.9.6 Addressing DONA and Network Failure

MKY44-MC01A has a function that constantly monitors the existence of another party issuing operation instructions to MKY44-MC01A.

This function monitors the formation of a link, which is a basic function of CUNet. In CUNet, the DOA (DO Arrival) state is when links are formed in 3 or more scans. MKY44-MC01A defines a state in which the DOA state has changed into a non-DOA state for at least 0.5 seconds as the DONA (DO Not Arrival) state (see Figure 1.25).

MKY44-MC01A will transition to the DONA state if it is isolated in the CUNet network (line disconnected). It is because it also cannot find the other party issuing operation instructions. In the DONA state, the High signal is output to the DONA terminal.

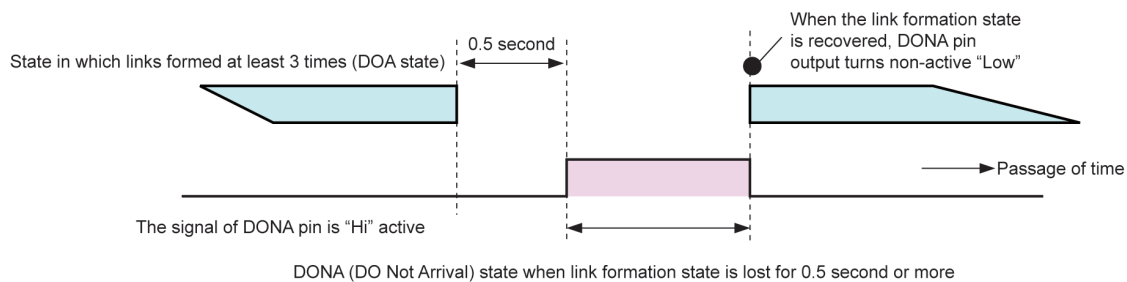

Fig. 1.25 Timing of DONA

If the DONA state is entered while an axis is operating, the operation will differ according to the setting state of the DONAS (DONA Stop) bit of the PG2 (Property Group 2) register. If the DONAS bit is “0”, operation will not be affected. If the DONAS bit is “1”, it will stop according to the stop type set in the STS (Stop Type Select) bit of the PG2 register. However, during distance specification upper speed movement (DS_UFlat) or target specification upper speed movement (TS_UFlat), it will immediately stop even if the STS bit is set to deceleration stop.

If the Do012C (Do012 Clear) bit of the PG2 register is set to “1”, “0” will be set in bits DOP0 to DOP2 of the COM register, which contains the general-purpose output data of pins Do0, Do1, and Do2, upon transition to the DONA state.

Even if there is a transition to the DONA state while an axis is being operated manually, manual operation will not stop immediately. However, you cannot start new manual operation during DONA state.



Reference

In the factory default setting, DONA stop is ON, and stop type is set to deceleration stop. The function of Do0, Do1, and Do2 clear by DONA is OFF.

1.10 Registers for Motion Control

In MKY44-MC01A, there are 16 registers for motion control as shown in Table 1-16. Each parameter for motion control described in this chapter is stored in these registers. User applications control motion by performing read/write access to these registers.

Table 1-16 Registers for Motion Control

Abbreviation	Register name	Target function	Usage and overview
AXS	AXis Status	Axis status etc.	Show the state of axis, sensor, and general-purpose Di/Do and the events of operation start or stop.
LPC	Logical Position Coordinates	Logical position coordinates	Show the coordinate corresponding to the output pulse count. -8,388,608 to +8,388,607
PPC	Physical Position Coordinates	Physical position coordinates	Show the input coordinate from encoder etc. -8,388,608 to +8,388,607
NS	Now Speed	Current speed	Show the speed of output pulse. 0 to 24,000 pps
COM	COMmand	Command	The register to issue instructions to the axis. Data setting to pattern memory number and general-purpose also use this register.
TPC	Target Position Coordinates	Target position coordinates	Set the target position coordinate -8,388,608 to +8,388,607
RAD	Relative / Absolute Distance	Distance	Set the relative distance (-8,388,608 to +8,388,607) or absolute distance (0 to 16,777,215).
LS	Lower Speed	Lower speed	Set the lower speed. Valid values are 10 to 24,000 pps.
US	Upper Speed	Upper speed	Set the upper speed. Valid values are 10 to 24,000 pps.
ACC	ACCeleration	Acceleration	Individually set plus acceleration (acceleration) to increase the speed and minus acceleration (deceleration) to decrease the speed using rate format or time format.
SCom	Synchronization Command	Synchronization command	Set the instructions to synchronize.
STS	Synchronization Trigger Setup	Synchronization trigger condition	Set the trigger conditions for shared data synchronization.
PLC	Plus Limit Coordinates	Plus limit coordinates	Set the plus limit coordinate. -8,388,608 to +8,388,607
MLC	Minus Limit Coordinates	Minus limit coordinates	Set the minus limit coordinate. -8,388,608 to +8,388,607
PG1	Property Group 1	Property group 1	Set speed range, speed transition curve, peak time of triangular drive prevention, and Do3 watchdog timer.
PG2	Property Group 2	Property group 2	Set options regarding the axis.

The patterns related to move instructions are TPC, RAD, LS, US, and ACC.

For how to access to the registers, the details of the registers, and the registers and operation of utility functions, see **“Chapter 2 How to Use MKY44-MC01A”**.

Chapter 3 MKY44-MC01A Hardware

This chapter describes the MKY44-MC01A hardware.

- 3.1 Pin Functions of MKY44-MC01A..... 3-4
- 3.2 Electrical Ratings of Pins 3-6
- 3.3 Pin Assignment 3-8
- 3.4 Connection of Basic I/O Signals 3-9
- 3.5 Connection of CUnet-related I/O Signals 3-12
- 3.6 I/O Signal of Axis Control Unit 3-15
- 3.7 Example of Connection Circuit..... 3-20
- 3.8 Electrical Ratings 3-21
- 3.9 Package Dimensions 3-22
- 3.10 Recommended Soldering Conditions 3-23
- 3.11 Recommended Reflow Conditions 3-23

Chapter 3 MKY44-MC01A Hardware

This chapter describes the MKY44-MC01A hardware.

Figure 3.1 shows a block diagram of MKY44-MC01A. MKY44-MC01A has a CUnet core, an axis control unit, and flash ROM. The axis control unit has pattern memory and a group of registers. The CUnet core and axis control unit are connected by the data of the registers.

MKY44-MC01A has I/O signals as shown in Figure 3.1. ST44SW is designed to assist MKY44-MC01A. It reads 16-bit DIP-SW and serves as a dedicated LSI for hardware setting.

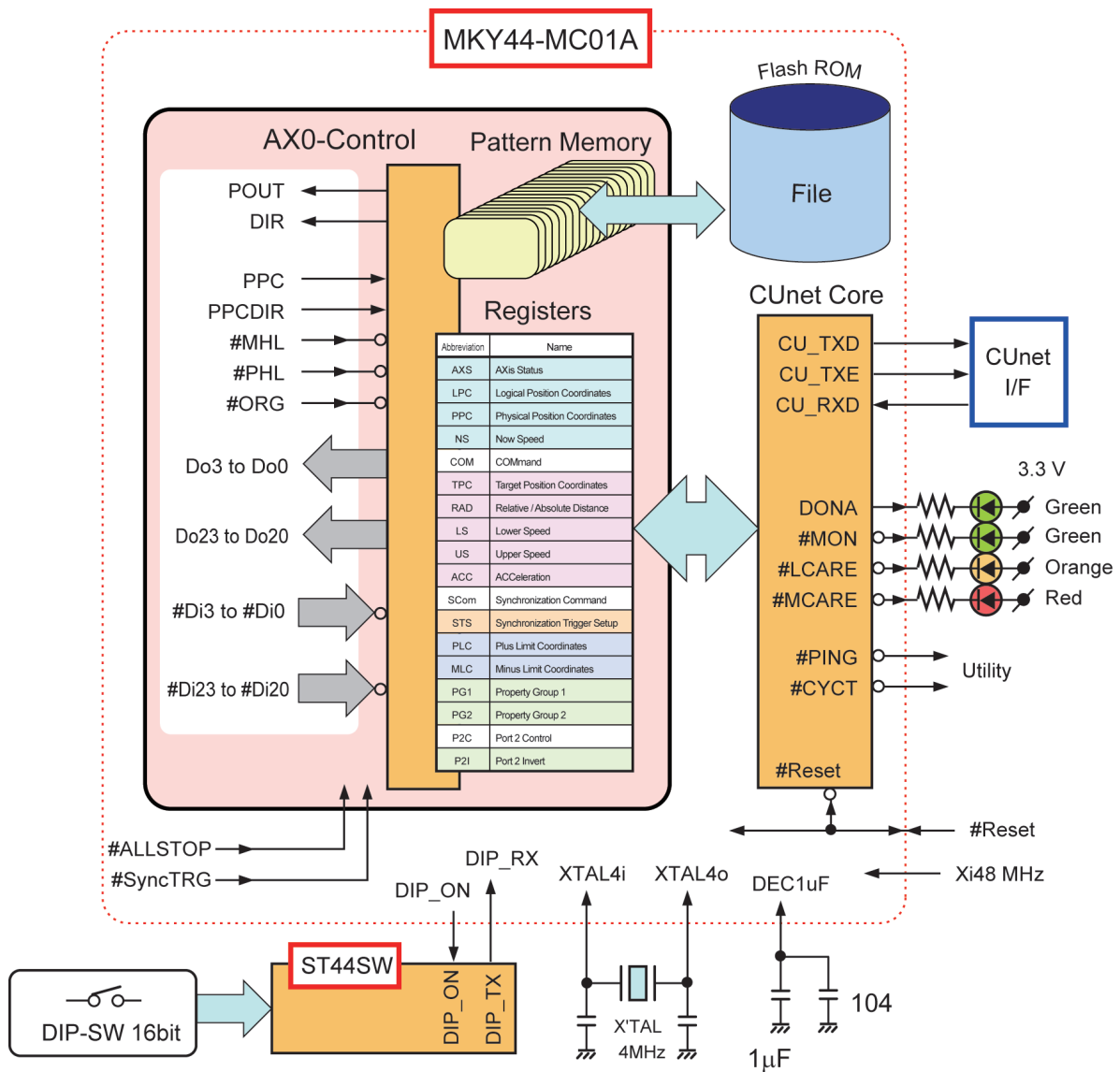

Fig. 3.1 Block Diagram of MKY44-MC01A

3.1 Pin Functions of MKY44-MC01A

Table 3-1 shows the pin functions of MKY44-MC01A.

Table 3-1 Pin Functions of MKY44-MC01A

Pin name	Pin number	Logic	I/O	Function
DEC1uF	3	---	---	Connect a capacitor whose effective capacitance is at least 1 μ F and a 0.1 μ F ceramic capacitor for high frequency bypass in parallel between this pin and Vss. Or connect a laminated ceramic capacitor of around 2.2 μ F with the property that capacitance reduction is about 20% even in DC bias.
#Reset	6	Negative	I/O	An input pin to execute hardware reset from outside. For details on this function, see "3.4.2 Supply of Hardware Reset Signal" .
XTAL4i XTAL4o	10, 11	---	---	Pins to connect a crystal oscillator. Connect a 4 MHz crystal oscillator between these pins. Connect 20 pF ceramic capacitors between these pins and Vss. Connect them near the pins.
DIP_ON	15	Positive	O	Connect this pin to the DIP_ON pin of ST44SW. For the details of ST44SW, refer to the manual "ST44SW User's Manual" .
DIP_RX	17	Positive	I	Connect this pin to the DIP_TX pin of ST44SW. For the details of ST44SW, refer to the manual "ST44SW User's Manual" .
#AX0_ORG	18	Negative	I	An input pin to connect the origin sensor signal of AX0. MKY44-MC01A recognizes that the sensor is active when the Low-level is input to this pin.
#AX0_PHL	19	Negative	I	An input pin to connect the plus hard limit sensor signal of AX0. MKY44-MC01A recognizes that the sensor is active when the Low-level is input to this pin.
#AX0_MHL	20	Negative	I	An input pin to connect the minus hard limit sensor signal of AX0. MKY44-MC01A recognizes that the sensor is active when the Low-level is input to this pin.
#AX0_Di0 to #AX0_Di3	27 to 30	Negative	I	General-purpose input pins of AX0. When the Low-level is input to this pin, "1" is shown in DIM bit in the register.
AX0_Do0 to AX0_Do3	31 to 34	Positive	O	General-purpose output pin bits of AX0. If the option to assign to the output of logical inversion or other functions is not set, this pin will output the High-level when "1" is set in the DOP bit of the COM register.
AX0_PPC	35	Positive	I	A clock input pin to count the PPC (Physical Position Coordinates) of AX0. PPC is counted when this pin transitions from Low-level to High-level.
AX0_PPCDIR	37	Positive	I	An input pin to determine addition or subtraction of the PPC (Physical Position Coordinates) of AX0. If this pin is Low-level when counting PPC, "1" will be added to PPC. If it is High-level, "1" will be subtracted.
AX0_DIR	39	Positive	O	An output pin to show the rotation direction of AX0. Normally, it shows CW (clockwise) when this pin is Lo (if the bit logical inversion option is not set).
AX0_POUT	41	Positive	O	A pulse output pin of AX0. It is in Low-level while stopped.
Do20 to Do23	43 to 46	Positive	O	Output pins of general-purpose port 2. If logical inversion is not set, this pin will output the High-level when "1" is set in the OP2 bit of the P2C register.
DONA	47	Positive	O	This pin retains the High-level while the DONA (DO Not Arrival) state continues. It is in Low-level in other cases.
#SyncTRG	48	Negative	I	An input pin of the synchronization trigger signal. MKY44-MC01A recognizes the time when this pin transitions to the Low-level from High-level as a synchronization trigger.
Xi48MHz	49	Positive	I	An input pin to supply the clock that drives the CUnet core of MKY44-MC01A. Connect the generated 48 MHz clock to this pin.

Table 3-1 Pin Functions of MKY44-MC01A

Pin name	Pin number	Logic	I/O	Function
#PING	50	Negative	O	A pin to output the PING signal, which is a standard function of CUNet. When the PING signal occurs, this pin transitions to Low-level.
#CYCT	51	Negative	O	A pin to output the CYCT signal, which is a standard function of CUNet. When the CYCT signal occurs, this pin transitions to Low-level.
#ALLSTOP	52	Negative	I	An input pin for the all stop signal. MKY44-MC01A recognizes that the all stop signal is active while this pin is in Low-level.
#MCARE	53	Negative	O	A pin to output the MCARE signal, which is a standard function of CUNet. This pin outputs the Low-level for about 50 ms, when the MCARE signal occurs and when it returns from hardware reset. This pin may also output the Low-level when indicating hardware errors, including setting mistakes. For details, see “3.5.2 Connection and Displayed States of LED Indicator Pins” .
#LCARE	54	Negative	O	A pin to output the LCARE signal, which is a standard function of CUNet. This pin outputs the Low-level for about 50 ms, when the LCARE signal occurs and when it returns from hardware reset. This pin may also output the Low-level when indicating hardware errors, including setting mistakes. For details, see “3.5.2 Connection and Displayed States of LED Indicator Pins” .
#MON	55	Negative	O	A pin to output the MON signal, which is a standard function of CUNet. This pin will retain the Low-level while there is stable link establishment with CUNet devices other than itself.
CU_TXD	56	Positive	O	An output pin to send CUNet packets. Connect this pin to a drive input pin such as of a driver.
CU_TXE	57	Positive	O	A pin to output the High-level while CUNet packets are output. Connect this pin to the enable input pin of the driver.
CU_RXD	58	Negative	I	A pin to input CUNet packets. Connect this pin to the output pin of the receiver.
#Di20 to #Di23	59 to 62	Negative	I	Input pins of general-purpose port 2. If logical inversion is not set, “1” is shown in the IP2M bit of the P2C register when the Low-level is input to this pin.
V _{DD}	1, 2, 4, 23			Power pin. Supply 3.3 V.
V _{SS}	5, 9, 12			Power pin. Connected to 0 V.
N.C.	7, 8, 13, 14, 16, 21, 22, 24, 25, 26, 36, 38, 40, 42, 63, 64			Do not connect to other signals; keep them open.

Note: Pins prefixed with “#” are negative logic (active Low).

3.2 Electrical Ratings of Pins

Table 3-2 shows the electrical ratings of the pins.

Table 3-2 Electrical Ratings of MKY44-MC01A

No	I/O	Name	Type	No	I/O	Name	Type	No	I/O	Name	Type	No	I/O	Name	Type
1	--	V _{DD}	--	17	I	DIP_RX	A	33	O	AX0_Do2	B	49	I	Xi48MHz	A
2	--	V _{DD}	--	18	I	#AX0_ORG	A	34	O	AX0_Do3	B	50	O	#PING	B
3	--	DEC1uF	--	19	I	#AX0_PHL	A	35	I	AX0_PPC	A	51	O	#CYCT	B
4	--	V _{DD}	--	20	I	#AX0_MHL	A	36	--	N.C.	--	52	I	#ALLSTOP	A
5	--	V _{SS}	--	21	--	N.C.	--	37	I	AX0_PPCDIR	A	53	O	#MCARE	B
6	I/O	#Reset	C	22	--	N.C.	--	38	--	N.C.	--	54	O	#LCARE	B
7	--	N.C.	--	23	--	V _{DD}	--	39	O	AX0_DIR	B	55	O	#MON	B
8	--	N.C.	--	24	--	N.C.	--	40	--	N.C.	--	56	O	CU_TXD	B
9	--	V _{SS}	--	25	--	N.C.	--	41	O	AX0_POUT	B	57	O	CU_TXE	B
10	--	XTAL4i	--	26	--	N.C.	--	42	--	N.C.	--	58	I	CU_RXD	A
11	--	XTAL4o	--	27	I	#AX0_Di0	A	43	O	Do20	B	59	I	#Di20	A
12	--	V _{SS}	--	28	I	#AX0_Di1	A	44	O	Do21	B	60	I	#Di21	A
13	--	N.C.	--	29	I	#AX0_Di2	A	45	O	Do22	B	61	I	#Di22	A
14	--	N.C.	--	30	I	#AX0_Di3	A	46	O	Do23	B	62	I	#Di23	A
15	O	DIP_ON	B	31	O	AX0_Do0	B	47	O	DONA	B	63	--	N.C.	--
16	--	N.C.	--	32	O	AX0_Do1	B	48	I	#SyncTRG	A	64	--	N.C.	--

Figure 3.2 shows the pin electrical characteristics in I/O circuit types in MKY44-MC01A.

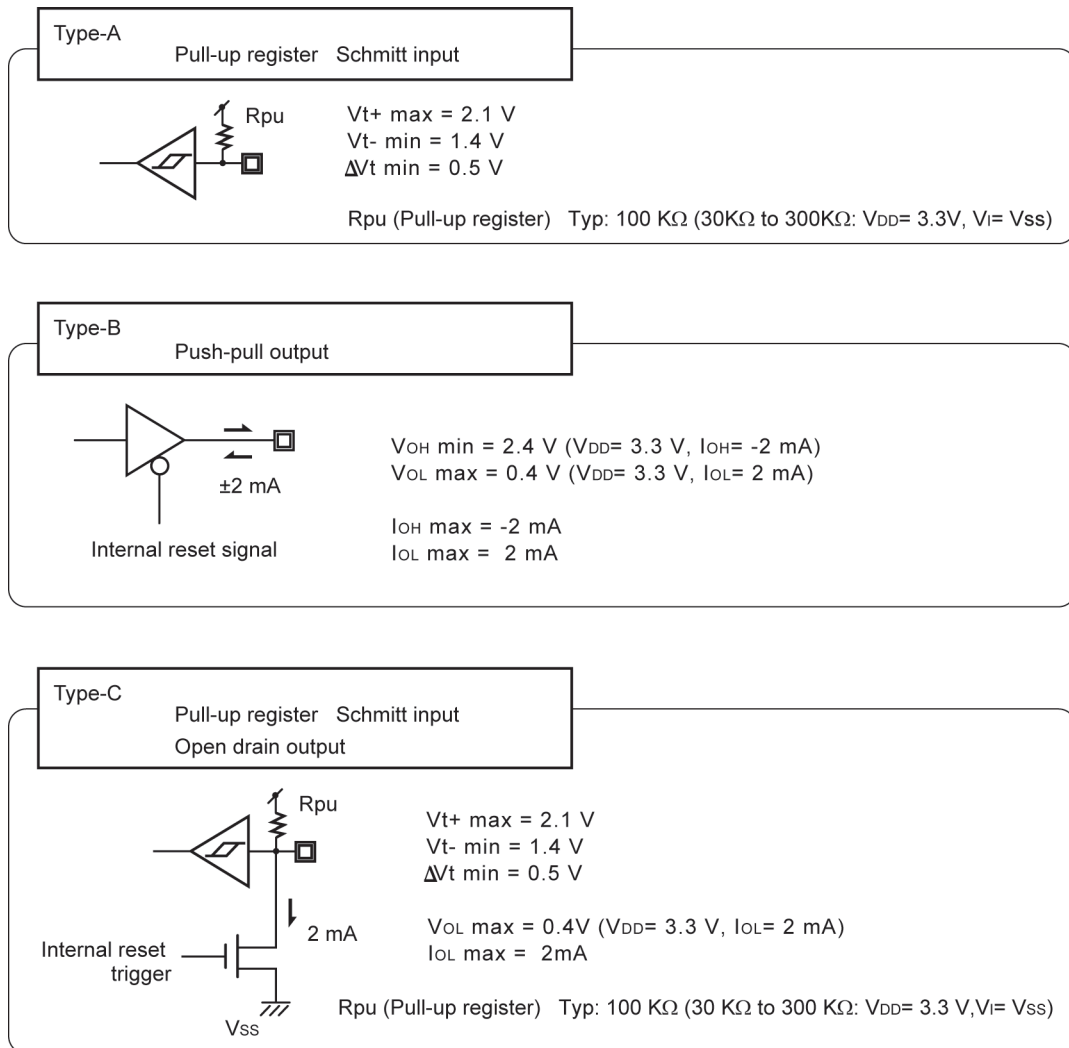

Fig. 3.2 Pin electrical characteristics in I/O circuit types of MKY44-MC01A

3.3 Pin Assignment

Figure 3.3 shows the pin assignment.

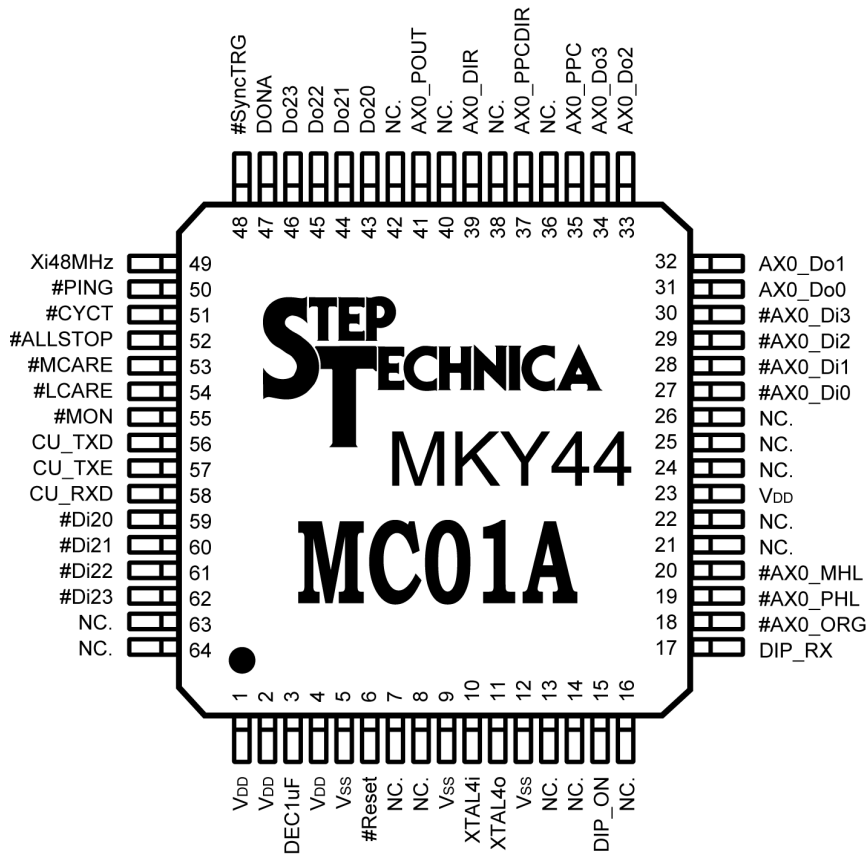

Fig. 3.3 Signal Assignment of MKY44-MC01A Pins

In the connection of MKY44-MC01A, make sure to connect all of the multiple V_{DD} pins (pins 1, 2, 4, and 23) to the 3.3 V power supply terminal and make sure to connect all of the multiple V_{SS} pins (pins 5, 9, and 12) to the 0 V power supply terminal. Keep the N.C. pin open.

Between the pin 2 V_{DD} and the pin 12 V_{SS}, connect a capacitor whose capacitance is at least 1 μF and a 0.1 μF ceramic capacitor for high frequency bypass in parallel for decoupling of the power supply. Generally, it is recommended to connect a capacitor of about 47 μF for decoupling in view of the allowable load for I/O pins.

Between the pin 3 DEC1uF and V_{SS}, connect a capacitor whose capacitance is more than 1 μF and a 0.1 μF ceramic capacitor for high frequency bypass in parallel for DC stabilization. Or connect laminated ceramic capacitor of around 2.2 μF with a property that capacitance reduction is about 20% even in DC bias.

 **Reference**

The DEC1uF pin has 1.8 V direct voltage. Generally, the types of capacitors to connect to this pin, which have 1 μF capacitance or more, include electrolytic capacitors and tantalum capacitors. Laminated ceramic capacitors can be also used. However, since they are used in DC bias state, their effective capacitance as capacitors differs from their rated value. Especially when using a laminated ceramic capacitor, it is recommended to select one with at least twice (2 μF) the rated value, anticipating capacitance reduction caused by DC bias state and thermal properties. For the performance of capacitors and usage in DC bias state, refer to the documents of the capacitor vendor.

3.4 Connection of Basic I/O Signals

This section describes basic I/O signal connection of MKY44-MC01A.

3.4.1 Supply of Drive Clocks

MKY44-MC01A requires two clocks.

Connect a 4 MHz crystal oscillator between the XTAL4i pin and the XTAL4o pin (see Figure 3.1). This allows MKY44-MC01A to generate a clock within itself. Connect 20 pF ceramic capacitors between these pins and Vss. Place these near the pins.

If you want to open the XTAL4o pin and provide a generated 4 MHz clock to the XTAL4Mi pin without using a crystal oscillator, provide a clock of the following specifications: The rising edge and falling edge are less than or equal to 5 ns. The minimum time at High-level or Low-level is greater than or equal to 45 ns. The jitter is less than or equal to 500 ps. The frequency accuracy is within ± 500 ppm.

Provide a 48 MHz clock of the following specifications to the Xi48 MHz pin using an oscillator or such: The rising edge and falling edge are less than or equal to 20 ns. The minimum time at High-level or Low-level is greater than or equal to 5 ns. The jitter is less than or equal to 250 ps. The frequency accuracy is within ± 500 ppm.

3.4.2 Supply of Hardware Reset Signal

If a Low-level signal is supplied to the #Reset pin (pin 6), MKY44-MC01A will perform hardware reset. To reset MKY44-MC01A properly, keep the Low-level when power voltage of this pin is lower than the predefined value, and provide the signal maintaining the Low-level for at least 200 μ s after the power voltage reaches the predefined voltage value.

If a hardware reset instruction is received from a user application, MKY44-MC01A will activate its internal reset trigger. At this time, the #Reset pin temporarily outputs a Low-level signal. The internal equivalent circuit is open drain output (see Figure 3.2-C). The time for outputting this Low-level is within 1 μ s. Therefore, for external parts to connect to this pin, select one in open drain format that can configure a wired OR of the Low-level.

Accordingly, it is recommended to connect a reset LSI of voltage detection type that can operate when the power voltage is reduced to this pin. Connect a reset LSI whose output is either open drain type or open collector type and that has a time limit function of at least 200 μ s.



Make sure that hardware reset becomes active right after power activation of MKY44-MC01A. MKY44-MC01A may be reset when a Low-level pulse of 200 μ s or less is input to this pin. Make sure to prevent input of unintended Low-level pulses from external noise etc.

3.4.3 Connection of Signal for Hardware Setting (Hexadecimal Setting Specifications)

When returning from hardware reset, MKY44-MC01A reads 16 bits of DIP-SW data for hardware setting as serial data from the dedicated LSI ST44SW.

To the DIP_ON pin of ST44SW, connect the output signal of the DIP_ON pin of MKY44-MC01A, pulled down by 10 kΩ resistance. To the DIP_RX pin of MKY44-MC01A, connect the signal output by the DIP_TX pin of ST44SW (see Figure 3.4).

For details on ST44SW and its hexadecimal setting specifications, refer to the separate volume “*ST44SW User’s Manual*”. It is recommended to connect two 8-bit type DIP-SWs to an ST44SW of hexadecimal setting specification. The pin where the DIP-SW of ST44SW is connected is pulled up internally when reading the DIP-SW. MKY44-MC01A recognizes the ON status (Low-level) as “1”.

Table 3-3 shows the definitions of the DIP-SW bits for hardware settings which are connected to the ST44SW of hexadecimal setting specification.

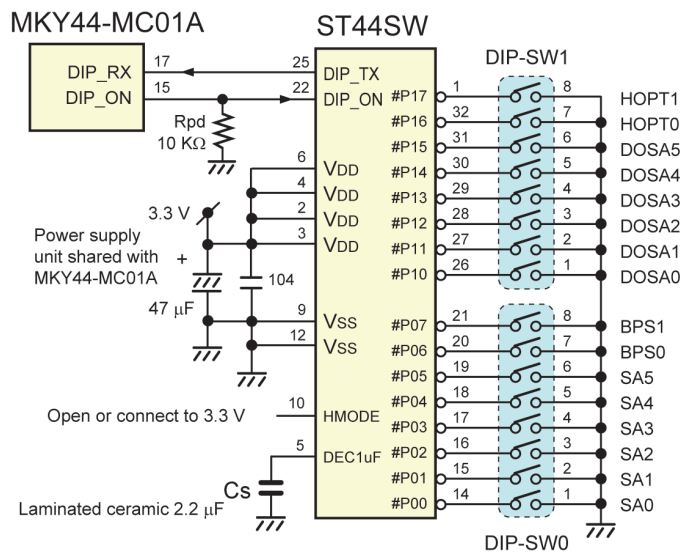

Fig. 3.4 Connection of DIP-SW and Read-Only LSI (Hexadecimal Setting Specifications)

Table 3-3 Settings of the DIP-SW Connected to ST44SW of Hexadecimal Setting Specifications

ST44SW		DIP-SW		Signal		Function/Description	
Pin	Name	No.					
1	#P17	DIP-SW1	8	HOPT1		Setting of Hardware OPTion 1. Set it OFF normally.	
32	#P16		7	HOPT0		Setting of Hardware OPTion 0. Set it ON to extend OWN area. For details, see “2.1.6 Extended CUnet Interface (Optional)”.	
31	#P15		DOSA	6	DOSA5	Set DOSA value in hexadecimal, treating the ON state as “1”. Regarding DOSA value, see “2.1 How to Access CUnet Interface and Registers”.	
30	#P14			5	DOSA4		
29	#P13			4	DOSA3		
28	#P12			3	DOSA2		
27	#P11			2	DOSA1		
26	#P10			1	DOSA0		
21	#P07	DIP-SW0	8	BPS	BPS1	Set the transfer rate of CUnet. BPS1, BPS0 = OFF, OFF 12 Mbps BPS1, BPS0 = OFF, ON 6 Mbps BPS1, BPS0 = ON, OFF 3 Mbps BPS1, BPS0 = ON, ON This setting is disabled.	
20	#P06		7		BPS0		
19	#P05		SA	6	SA5		Set SA value in hexadecimal recognizing ON state as “1”. Regarding SA value, see “2.1 How to Access CUnet Interface and Registers”.
18	#P04			5	SA4		
17	#P03			4	SA3		
16	#P02			3	SA2		
15	#P01			2	SA1		
14	#P00	1		SA0			

3.4.4 Connection of Signal for Hardware Setting (Decimal Setting Specifications)

ST44SW has a mode that can change SA setting and DOSA setting to decimal setting specification. Figure 3.5 shows the connection of ST44SW for decimal setting specifications.

Connect the HMODE pin of ST44SW to GND. It is recommended to connect a 2-digit decimal rotary DIP-SW to an ST44SW of decimal setting specification for SA and DOSA. It is also recommended to connect a 4-bit DIP-SW to an ST44SW of decimal setting specification for HOPT1,0 and BPS1,0 settings.

To the DIP_ON pin of ST44SW, connect the output signal of the DIP_ON pin of MKY44-MC01A, pulled down by 10 kΩ resistance. To the DIP_RX pin of MKY44-MC01A, connect the signal output by the DIP_TX pin of ST44SW. For details on ST44SW, refer to the separate volume **“ST44SW User’s Manual”**.

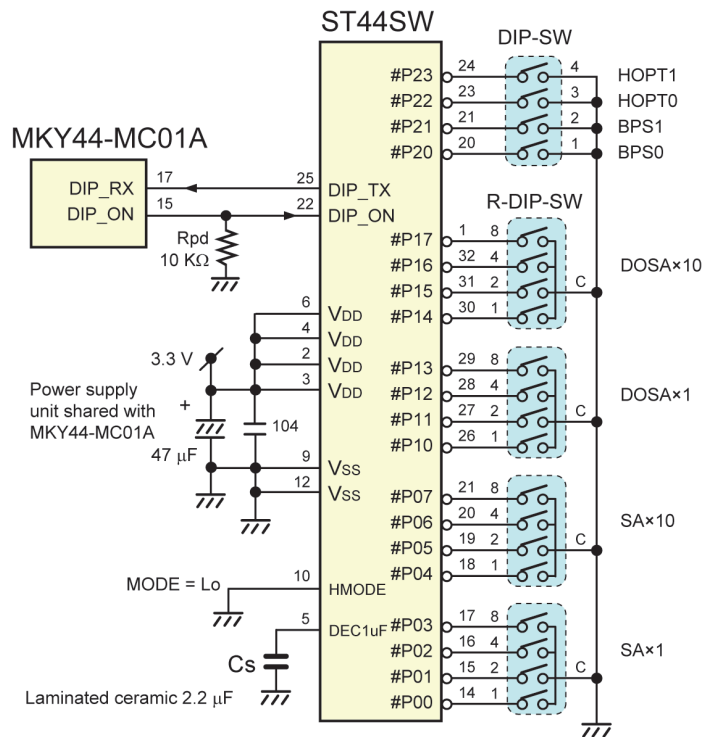

Fig. 3.5 Connection of DIP-SW and Read-only LSI (Decimal Setting Specifications)

In the following cases, serial output of properly serialized set data cannot be obtained from an ST44SW of decimal setting specification.

- (1) When the setting values of “0x0A to 0x0F” are recognized in the #P00 to #P03, #P04 to #P07 pins, #P10 to #P13 pins, and #P14 to #P17 pins.
- (2) When a setting value of more than “64” is recognized as a 2-digit decimal number in the #P00 to #P07 pins or #P10 to #P17 pins.

MKY44-MC01A handle these cases as hardware errors of the DIP-SW read system. When this happens, MKY44-MC01A can use the LED indicator pins to flash the LCARE and MCARE LEDs alternately every second. For more on LED indicator pins, see **“3.5.2 Connection and Displayed States of LED Indicator Pins”**.

Reference

If the LED of LCARE and MCARE flashes alternately every second, first check the setting status of the ST44SW of decimal setting specification.

3.5 Connection of CUnet-related I/O Signals

CUnet interface signals include the CU_TXD, CU_TXE, and CU_RXD pins of MKY44-MC01A. MKY44-MC01A also has four pins connecting monitor LEDs (#MON, #LCARE, #MCARE, and DONA) and two utility function output pins (#PING and #CYCT).

3.5.1 Recommended Network Connection

MKY44-MC01A receives packets sent from other CUnet stations through the CU_RXD pin and outputs packets to send to other CUnet stations through the CU_TXD pin. While sending packets, the High-level is output from the CU_TXE pin. Therefore, design the transceiver so that, when the CU_TXE pin becomes High-level, the enable pin of the driver becomes active and the serial pattern of packets output from the CU_TXD pin can be sent to the network. In MKY44-MC01A, the maximum signal speed of CU_TXD and CU_RXD is 12 Mbps (signal width is about 83 ns). Connect transceiver parts that can follow this signal.

Figure 3.6 shows the recommended network connection. The transceiver components consists of an RS-485-based driver/receiver and a pulse transformer. Recommended network cables include Ethernet LAN cable (10BASE-T, Category 3 or higher) and shielded network cables. Use one twisted-pair cable in the network cable.

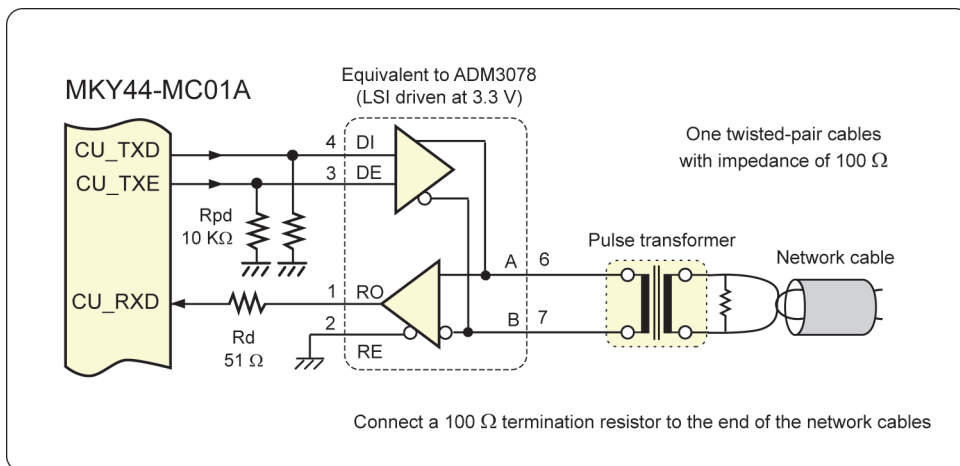

Fig. 3.6 Recommended Network Connection

Reference

Depending on the TRX configuration in half-duplex mode, signals output from the CU_TXD pin may be output directly to the CU_RXD pin while the MKY44-MC01A transmits packets. However, the MKY44-MC01A is designed not to receive any packet transmitted by itself while the CU_TXE pin is High, so there is no problem.

Background information to help build a network are described in **“CUnet Technical Guide”**. For more information about how to select components or to get recommended components, visit our Web site at www.steptecnica.com/.

3.5.2 Connection and Displayed States of LED Indicator Pins

MKY44-MC01A has four output signals for LEDs (#MON, #LCARE, #MCARE, and DONA). These pins have ± 2 mA current drive capability. If an LED can light up with 2 mA current or less, it must be connected in such a way that it will light up when in Low-level.

It is recommended to connect green LED parts indicating stable operation to the #MON pin and DONA pin. To the #LCARE pin, it is recommended to connect an orange LED part indicating a gentle warning. To the #MCARE pin, it is recommended to connect a red LED part indicating a definite warning.

Table 3-4 shows the state of MKY44-MC01A indicated by the LED indicators. Since “#” means a pin name representing negative logic, it is recommended not to put “#” when impressing the LED name on the board or the device. The state in which MON and DONA light up is when normal operation is possible.

Table 3-4 States of MKY44-MC01A Displayed by LED Indicators

DONA	MON	LCARE	MCARE	State
---	---	---	---	Indicates the state of power off, the state when the #Reset pin is active, or the state when no CUNet device is linked after returning from hardware reset.
---	●	---	---	Although a link is established with at least one CUNet device, there is no party (device of station address set by DOSA) that issues operation instructions to MKY44-MC01A.
●	●	---	---	The connection of the CUNet network is normal. The user application should execute appropriate operation.
---	---	---	●	The setting values of SA and DOSA of DIP-SW are inappropriate.
---	---	□	---	When a state of no link establishment is newly recognized for at least one CUNet link destination, the LED flashes about 50 ms.
---	---	---	□	When a state of no link establishment in three consecutive scans is newly recognized for at least one CUNet link destination, the LED flashes about 50 ms.
---	---	□	□	When a disconnection in three consecutive scans is recognized for at least one CUNet link destination, and when a hardware rest is performed, the LEDs flash about 50 ms.
---	---	▲	▲	The following internal hardware of MKY44-MC01A is abnormal. Alternating lit and unlit every 1 second \Rightarrow DIP-SW read system hardware including ST44SW Alternating lit and unlit every 2 seconds \Rightarrow Internal flash ROM hardware Alternating lit and unlit every 3 seconds \Rightarrow Internal memory and circuit hardware Please perform maintenance such as replacement.

●: Continuous lighting □: Flash lighting for about 50 ms ▲: Alternating lit and unlit every few seconds

The state in which only MCARE stays lit means that the settings of SA and DOSA of DIP-SW are inappropriately identical or overlapping values. If LCARE and MCARE keep blinking every few seconds, it is a failure caused by a crash in MKY44-MC01A. Perform maintenance such as replacement. For other details on MON, LCARE, and MCARE, refer to sections such as **“Quality Control and Indication of Network”** for the CUNet-dedicated LSI installed in the device to issue control commands to MKY44-MC01A. When not using the #MON, #LCARE, #MCARE, and DONA pins, keep them open.



Reference

Besides these LEDs, it is recommended to equip an LED indicating the power-on state. The DONA signal is the same as that of MKY46.

3.5.3 PING Signal

The PING signal is one of the utility functions related to CUnet in MKY44-MC01A. The PING signal can be controlled by any of the CUnet stations, including CUnet stations that issue control commands to MKY44-MC01A, when MKY44-MC01A is connected by CUnet. The #PING pin, from which the negative logic of the PING signal is output, normally maintains High-level. If it receives a PING instruction from another CUnet station, it will transition to Low-level. If it receives a packet in which no PING instruction from another CUnet station to MKY44-MC01A is embedded, it will transition to High-level.

In the CUnet protocol, the purpose and destination of the PING signal are not specified. The PING signal is a supplementary extended function that helps building user applications.

For details on the PING signal, refer to “Sections Related to PING” for the CUnet-dedicated LSI installed in the device to issue control commands to MKY44-MC01A. When not using #PING pins, keep them open.

3.5.4 CYCT signal

The CYCT signal is one of the utility functions related to CUnet in MKY44-MC01A. The #CYCT pin, from which the negative logic of CYCT signal is output, normally maintains High-level, and it outputs Lo pulse for “ $2 \times Tbps$ ” of time at the lead timing of the CUnet cycle. By using the timing at which this signal transitions to Low-level, the user device can recognize a common timing (synchronization) for all CUnet stations connected to the network. The synchronization capability of CUnet can be calculated with Formula 3.1. When not using the #CYCT pins, keep them open.

Formula 3.1 [within] ($2 \times Tbps$) + (cycle time \times clock accuracy) + signal propagation delay

For example, under the conditions of 12 Mbps ($Tbps = 83.3 \text{ ns}$), 64 CUnet stations (cycle time = 2.365 ms), drive clock accuracy of 200 ppm (0.02%), cable (7 ns/m) total length of 100 m, maximum 50 ns send signal transit delay in transceiver parts (ADM3078E), and maximum 75 ns receive signal transit delay (ADM3078E), the synchronization capability is within ($167 \text{ ns} + 473 \text{ ns} + 700 \text{ ns} + 50 \text{ ns} + 75 \text{ ns}$) $\approx 1.465 \mu\text{s}$.



If a HUB is inserted in the network, this formula does not apply.



The function of the #CYCT pin in MKY44-MC01A is the same as the function of the #CYCT pin in MKY43 and MKY46 and the function of the #STB pin in MKY40.

3.6 I/O Signal of Axis Control Unit

In the axis control unit of MKY44-MC01A, signals include POUT, DIR, PPC, PPCDIR, #ORG, #PHL, #MHL, #Di0 to #Di3, Do0 to Do3, #Di20 to #Di23, and Do20 to Do23 (see Figure 3.1).

3.6.1 Connection of Motion Control Output Signals

Connect the signals output from the POUT pin and DIR pin of MKY44-MC01A, after converting them into electrical signals suitable for the motor drivers of the user application device.

The POUT signal output from the axis control unit normally retains the Lo signal when it is not active. However, the POUT pin enters a high impedance state during hardware reset of MKY44-MC01A (see Figure 3.2 Type B). The DIR pin also enters a high impedance state during hardware reset.

Therefore, ensure a level in which the circuit connected to the exterior would not become active during hardware reset by connecting pull-down resistance or pull-up resistance to the pin. Figure 3.7 shows an example of a circuit that retains Low-level during hardware reset.

The speed of the pulse signal to be output from the POUT pin is 24 kHz at a maximum. The minimum width specification of High-level pulse is 19 μ s (see Figure 3.8). Use an external circuit to connect to the POUT pin that can address this speed.

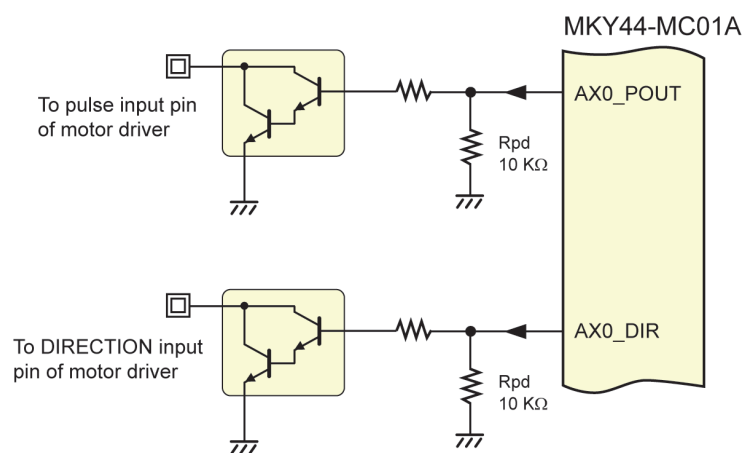

Fig. 3.7 Example Output Circuit to Ensure Initial Low-level

The DIR pin outputs the Low-level in the positive direction and the High-level in the negative direction. If the InvMD bit of the PG2 (Property Group 2) register is set to “1”, the levels will be inverted.

If the Do2FS bit of the PG2 register is set to “1”, the operating signal of the axis will be output to the Do2 pin (see Figure 3.8). Also, if the SCDo3 bit of the PG2 register is set to “1”, the axis will operate only when Do3 is active. The related signals of DIR, Do2, and Do3 will not transition for 10 μ s before and after the pulse is output to the POUT pin.

The output signal level of the Do2 pin will be inverted if the InvDo012 bit of the PG2 register is set to “1”. The output signal level of the Do3 pin will be inverted if the InvDo3 bit of the PG2 register is set to “1”.

The Do2 pins and Do3 pins enter a high impedance state during hardware reset of MKY44-MC01A (see Figure 3.2 Type B). Therefore, connect to the pin either pull-down resistance or pull-up resistance that can ensure initial levels suitable for the user application device.

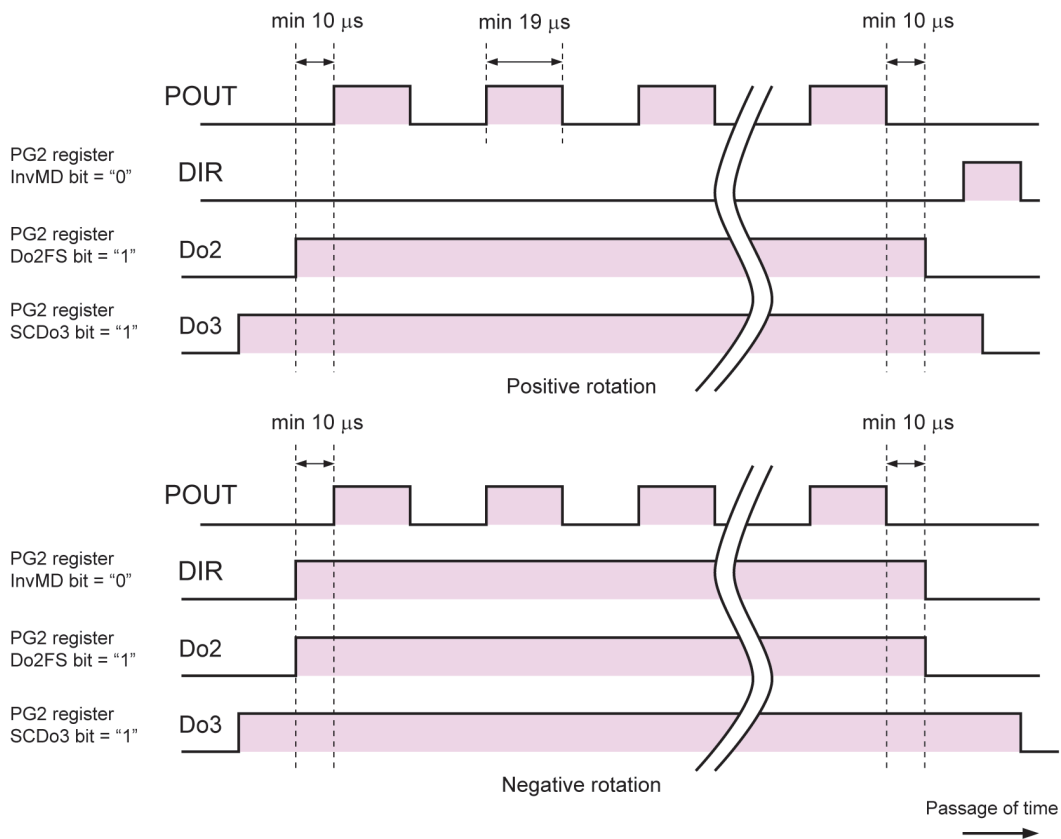

Fig. 3.8 Motion Control Output Signal of Positive/Negative Rotation

When the input signal to the motor driver of the user application device is not the pair of pulse signal and direction signal, but the pair of positive direction pulse signal and negative direction pulse signal, it can be converted simply by adding a gate circuit (see Figure 3.9).

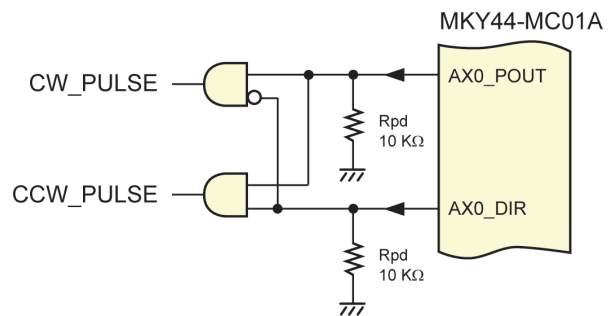

Fig. 3.9 Example of Circuit Conversion for CW and CCW Pulse Format

3.6.2 Input Signal Connection for Physical Position Coordinates

Connect clock signals generating physical position coordinates for encoders to the PPC pin of MKY44-MC01A and connect a status signal that adds and subtracts clocks to the PPCDIR pin.

MKY44-MC01A adds one to the physical position coordinate if the PPCDIR pin is Low-level right after PPC pin input transitions from Low-level to High-level. If it is High-level, MKY44-MC01A subtracts one from the physical position coordinate.

The logic of the PPCDIR pin that determines addition and subtraction of physical position coordinates can be inverted by setting “1” to the InvPPD (Invert Physical Pulse Direction) bit of the PG2 (Property Group 2) register.

The speed of the clock to input to the PPC pin is 24 kpps (24 kHz) at a maximum. There is no minimum. The minimum width of High-level and Low-level is 20 μ s. Retain the signal of direction to input to the PPCDIR pin for at least 41.6 μ s from when the PPC pin input signal transitions from Low-level to High-level.

When not using the PPC input pin and PPCDIR input pin, keep them open.

If the signal of the user application device does not have the signal format of pulse and direction, but the phase difference signal format of Phase A and Phase B, it can be adjusted by adding a gate circuit (see Figure 3.10).

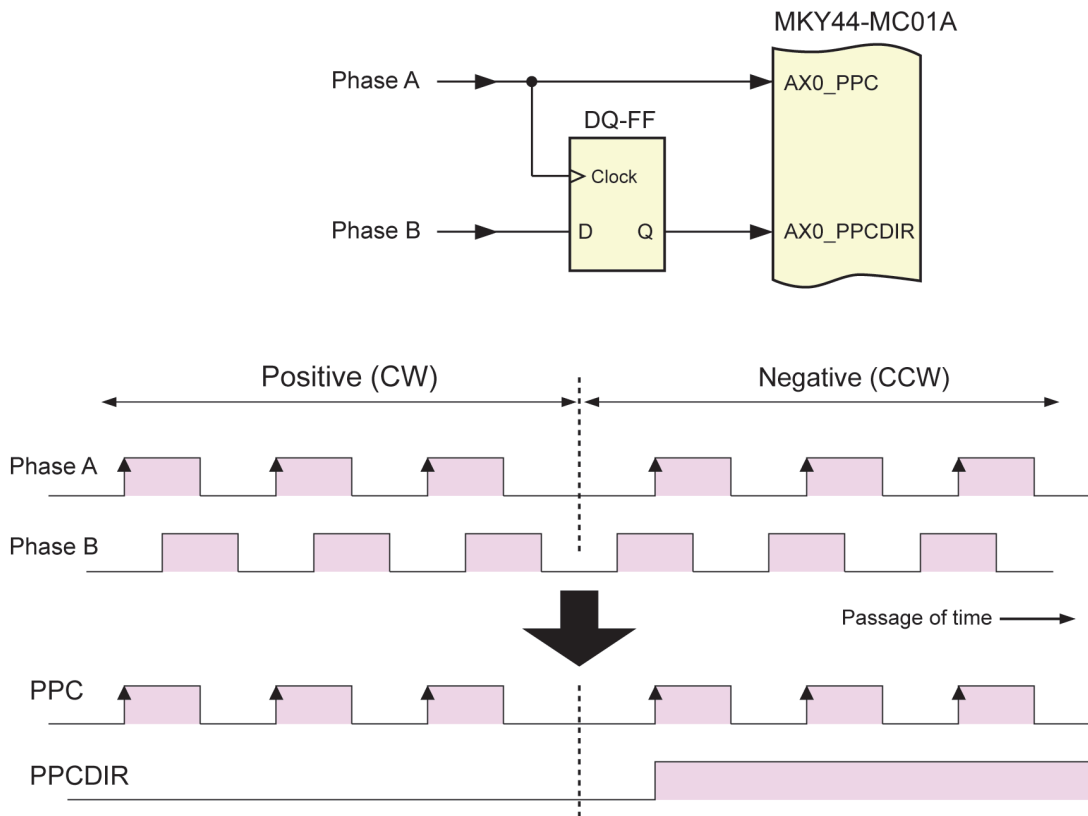

Fig. 3.10 Example of Circuit Conversion from Phase Signal Format

3.6.3 Input Signal of Sensors

Connect the signal of the origin sensor to the #ORG pin of MKY44-MC01A. Connect the signal of the plus hardware limit sensor to the #PHL pin. Connect the signal of the minus hardware limit sensor to the #MHL pin. In each case, connect a signal whose Low-level is active. If a process such as chattering elimination is required because the sensor is located at a mechanical junction, input a processed signal.

When not using the #MHL input pin, #PHL input pin, or #ORG input pin, keep it open.

For the role of the origin sensor, see **“1.4 Origin Detection”**. For the role of hardware limit sensors, see **“1.5 Stop Functions”**.

3.6.4 General-Purpose Input for Axis Control (#Di0 to #Di3)

MKY44-MC01A has four pins (#Di0 to #Di3) as general-purpose input pins for axis control. When pins #Di0 to #Di3 are Low-level, the DIM bit of the the register shows “1”. If a process such as chattering elimination is required because the signal source connected to a pin is located at a mechanical junction, input a processed signal. When not using these input pins, keep them open.

Pin #Di0 is shared with EZ (Encoder Zero) sensor input. Pin #Di1 is shared with stop signal input. Pin #Di2 is shared with the plus stop sensor and manual plus direction SW. Pin #Di3 is shared with the minus stop sensor and manual minus direction SW (see Table 3-5).

Table 3-5 General-Purpose I/O Pin and Shared Functions

Pin	Function 1	Function 2	Function 3
#Di0	General-purpose input	EZ (Encoder Zero) sensor	---
#Di1		Stop signal input	---
#Di2		Plus stop sensor	Manual plus direction SW
#Di3		Minus stop sensor	Manual minus direction SW
Do0	General-purpose output	---	---
Do1		---	---
Do2		Axis operating signal	---
Do3		Watchdog timer output	---

The selection of shared pins #Di3 and #Di2 can be set with the Di23FS bit of the PG2 (Property Group 2) register. The selection of shared pin #Di1 can be set with the Di1F bit of the PG2 register.

There is no selection setting for shared pin #Di0. It recognizes the pin #Di0 input as the EZ sensor only when Origin Search 3 instruction is executed. Therefore, connect an EZ sensor to pin #Di0 for user applications that often use an EZ sensor.

3.6.5 General-Purpose Output for Axis Control (Do0 to Do3)

MKY44-MC01A has four pins (Do0 to Do3) as general-purpose output pins for axis control. Shared functions are attached to some of pins Do0 to Do3 for the purposes of logical inversion and control. When not using shared functions for logical inversion and control, write “1” in the DOP bit of the COM register and the High-level will be output to pins Do0 to Do3. After hardware reset, the DOP bits of registers are all “0”.

Pin Do2 is shared with the output of the axis operating signal (see Table 3-5). For details on the function of pin Do2, see “**3.6.1 Connection of Motion Control Output Signals**” and “**1.9.3 Output Signal Indicating Axis Operating**”. The selection of shared pin Do2 can be set with the Do2FS bit of the PG2 (Property Group 2) register.

The output level of pins Do0, Do1, and Do2 can be inverted relative to the internal logic definitions. This can be set with the InvDo012 bit of the PG2 register. When issuing the patternSave (0x1F) command to the COM register after setting inversion, the initial state after hardware reset will become High-level.

Pin Do3 can be used as a watchdog timer. For the details of the function of pin Do3, see “**3.6.1 Connection of Motion Control Output Signals**” and “**1.9.4 Do3 Watchdog Timer Function**”. The output level of pin Do3 can be inverted relative to the internal logic definition. This can be set with the InvDo3 bit of the PG2 register. When issuing the patternSave (0x1F) command to the COM register after setting inversion, the initial state after hardware reset will become High-level.

Output pins Do0 to Do3 are in a high impedance state during hardware reset of MKY44-MC01A (see Figure 3.2 Type B). Therefore, connect to the pins either pull-down resistance or pull-up resistance that can ensure the initial levels suitable for the user application device. When not using these output pins, keep them open.

3.6.6 General-purpose I/O Pin without Shared Functions

In MKY44-MC01A, pins #Di20 to #Di23 are general-purpose input ports without shared functions, and pins Do20 to Do23 are general-purpose output ports without shared functions. These are called “port 2”.

The general-purpose I/O port 2 without shared functions can set logical inversion for each bit using the P2I (Port 2 Invert) register.

Control of the general-purpose I/O port without shared functions (Port 2) can be executed by the P2C (Port 2 Control) register. For specific information about the use of the register, see “**2.2.3.15 Description of Register P2C**” and “**2.2.3.16 Description of Register P2I**”.

Output pins Do20 to Do23 are in a high impedance state during hardware reset of MKY44-MC01A (see Figure 3.2 Type B). Therefore, connect to the pins either pull-down resistance or pull-up resistance that can ensure initial levels suitable for the user application device. When not using these output pins, keep them open.

3.7 Example of Connection Circuit

Figure 3.11 shows an example of a circuit connected as described in this section. The ST44SW shown in the figure has hexadecimal setting specifications.

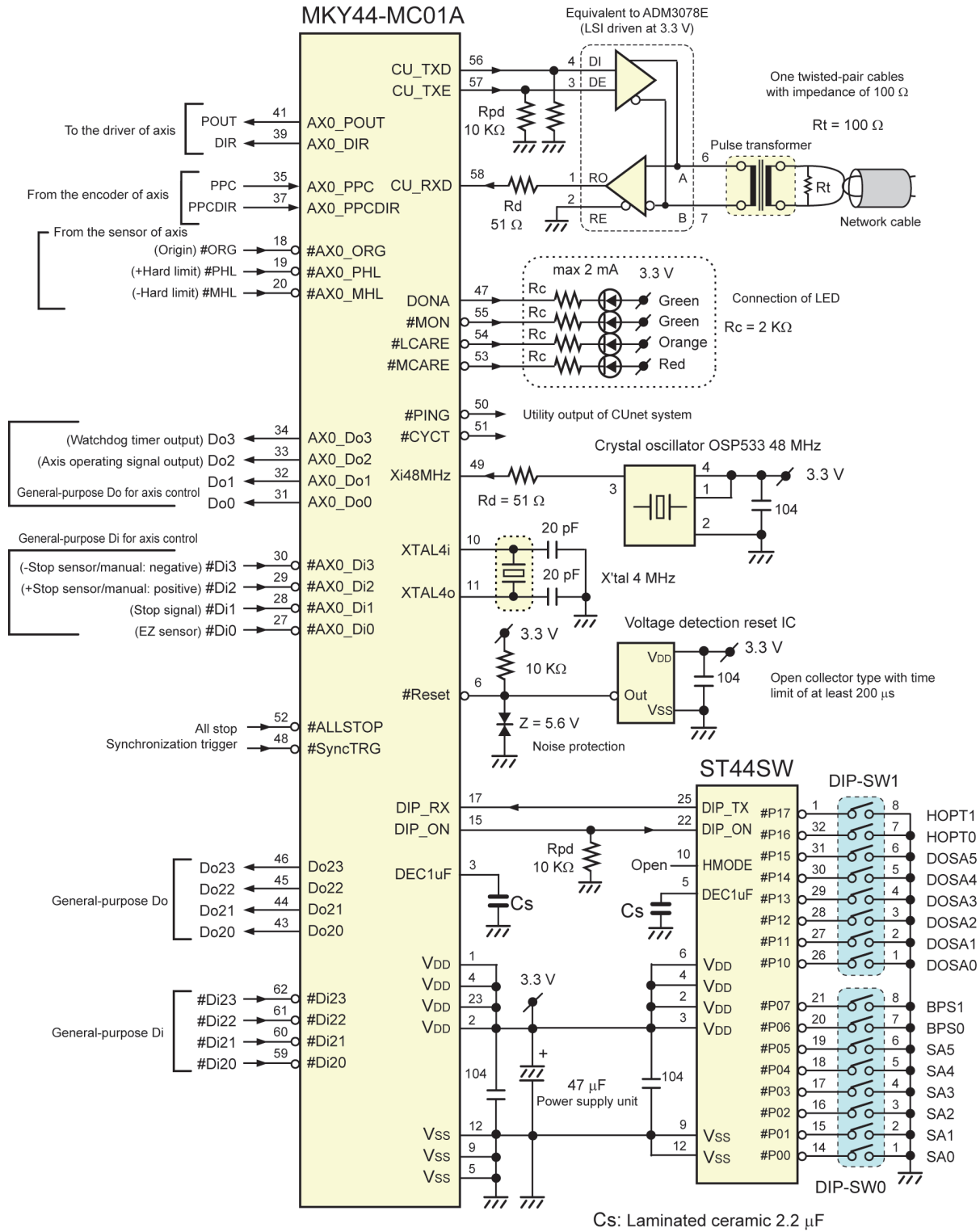

Fig. 3.11 Example of MKY44-MC01A Circuit Connection

3.8 Electrical Ratings

Table 3-6 lists the absolute maximum ratings of the MKY44-MC01A.

Table 3-6 Absolute Maximum Ratings

($T_A = 25^\circ\text{C}$ $V_{SS} = 0\text{ V}$)

Parameter	Symbol	Rating	Unit
Power supply voltage	V_{DD}	-0.3 to +4.6	V
Input voltage	V_i	$V_{SS} - 0.3$ to +3.6	V
Output voltage	V_o	$V_{SS} - 0.3$ to +3.6	V
Peak output current	I_{op}	± 10	mA
Total output current of all pins	I_{to}	± 60	mA
Allowable power dissipation ($T_A = +85^\circ\text{C}$)	PT	240	mW
Operating temperature	T_{opr}	-40 to +85	$^\circ\text{C}$
Storage temperature	T_{stg}	-55 to +125	$^\circ\text{C}$

Table 3-7 lists the electrical ratings of the MKY44-MC01A.

Table 3-7 Electrical Ratings

($T_A = 25^\circ\text{C}$ $V_{SS} = 0\text{ V}$)

Parameter	Symbol	Conditions	Min.	Typ.	Max.	Unit
Operating power supply voltage	V_{DD}	---	3.0	3.3	3.6	V
Mean operating current	V_{DDA}	$V_i = V_{DD}$ or V_{SS} , output open $X_{i48\text{MHz}} = 50\text{ MHz}$ $XTAL = 4\text{ MHz}$	---	10	20	mA
External input frequency	Fclk	Input to $X_{i48\text{MHz}}$ pin	---	48	50	MHz
I/O pin capacitance	$C_{i/o}$	$V_{DD} = V_i = 0\text{ V}$ $X_{i48\text{MHz}} = 1\text{ MHz}$	---	10	---	pF
Rise/fall time of input signal	Ticlk	When inputting generated clock of $XTAL_{i4}$ pin	---	---	5	ns
Rise/fall time of input signal	Tirf	Schmitt trigger input	---	---	100	ms
Number of times of file saving instruction in built-in flash ROM	FROMw	---	---	---	1000	times
Number of years of Data retention in built-in flash ROM	FROMy	---	10	---	---	year

3.9 Package Dimensions

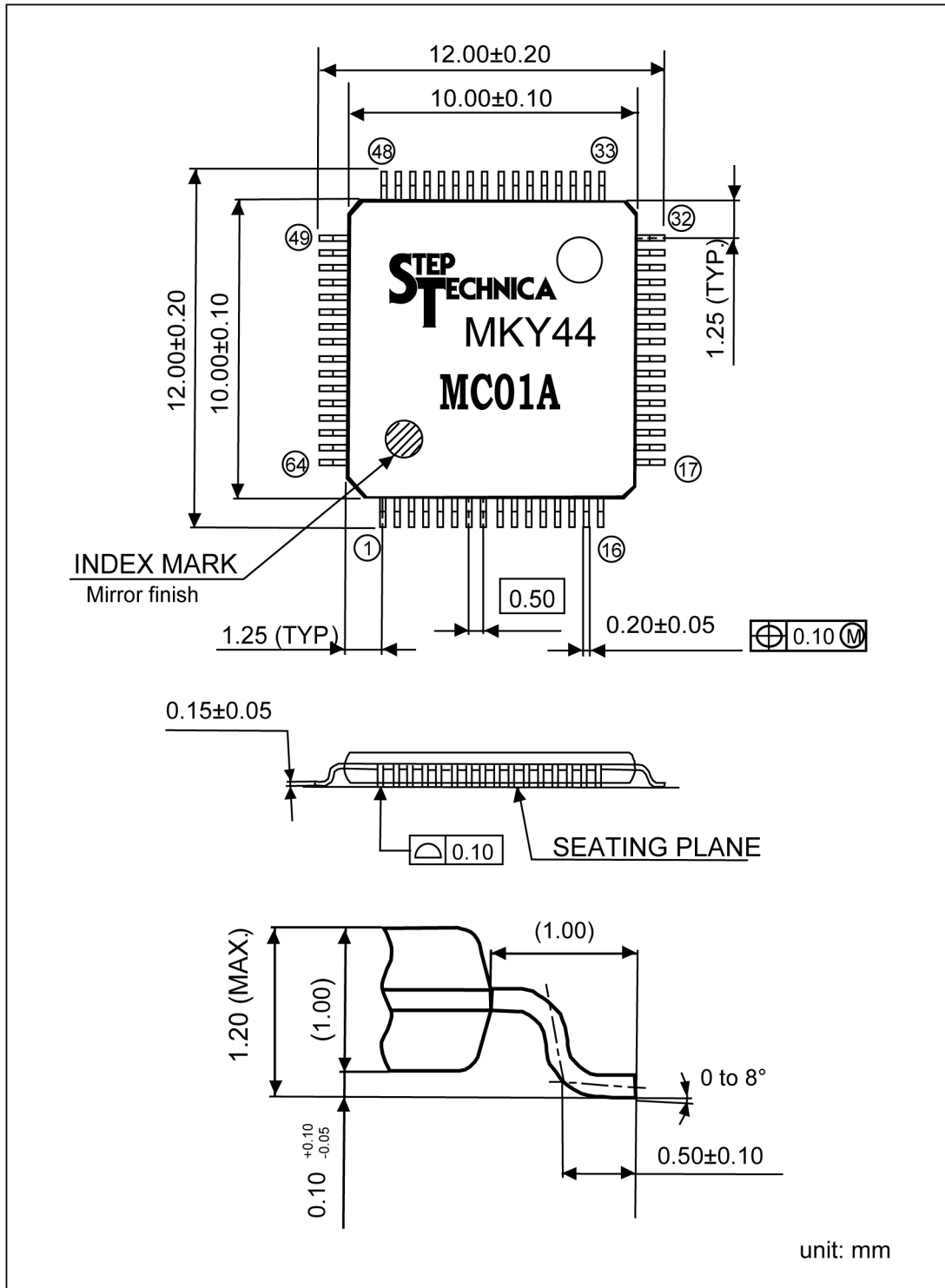

3.10 Recommended Soldering Conditions

Parameter	Symbol	Reflow	Manual soldering iron
Peak temperature (resin surface)	T_p	260°C max.	350°C max.
Peak temperature holding time	t_p	10 s max.	3 s max.



- (1) Product storage conditions: $T_A = 30^\circ\text{C}$ max., $RH = 70\%$ for prevention of moisture absorption
- (2) Manual soldering: Temperature of the tip of soldering iron 350°C , 3 s max.
(Device lead temperature 260°C , 10 s max.)
- (3) Reflow: Twice max.
- (4) Flux: Non-chlorine flux (should be cleaned sufficiently)
- (5) Ultrasonic cleaning: Depending on frequencies and circuit board shapes, ultrasonic cleaning may cause resonance, affecting lead strength

3.11 Recommended Reflow Conditions

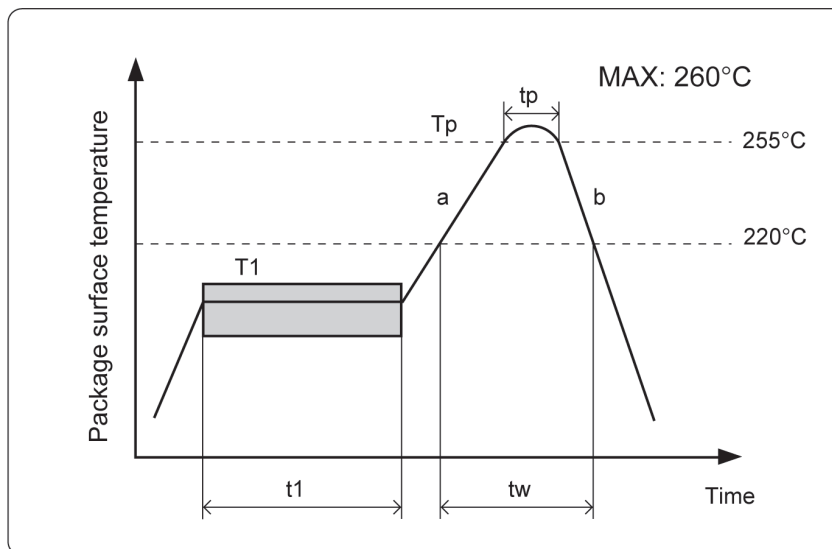

Parameter	Symbol	Value
Pre-heat (time)	t_1	60 to 120/s
Pre-heat (temperature)	T_1	150 to 180°C
Temperature rise rate	a	2 to 5°C/s
Peak condition (time)	t_p	10 s max.
Peak condition (temperature)	T_p	$255 + 5^\circ\text{C}$, -0°C
Cooling rate	b	2 to 5°C/s
High temperature area	t_w	220°C , 60 s max.
Removal temperature	T_2	$\leq 100^\circ\text{C}$



The recommended conditions apply to hot-air reflow or infrared reflow. Temperature indicates resin surface temperature of the package.

Chapter 2 How to Use MKY44-MC01A

This chapter describes how to use MKY44-MC01A.

- 2.1 How to Access CUnet Interface and Registers 2-4
- 2.2 Internal Registers of MKY44-MC01A 2-14
- 2.3 Commands of MKY44-MC01A 2-29
- 2.4 Errors and Error Notification..... 2-33
- 2.5 Motion Events 2-35
- 2.6 Exceptional Operation 2-36
- 2.7 Operation Procedure of MKY44-MC01A..... 2-37
- 2.8 Addressing CUnet Mail Function..... 2-39

Chapter 2 How to Use MKY44-MC01A

This chapter describes how to use MKY44-MC01A.

MKY44-MC01A is operated by access through CUnet as an interface. The foundation of MKY44-MC01A is to “instruct operations by setting parameters”.

Specific operations for “setting parameters” and “instructing operations” are performed by setting the data in the MKY44-MC01A registers via the CUnet interface. Likewise, specific operations for user applications to acquire MKY44-MC01A’s status or the coordinate data of axes are performed by reading the MKY44-MC01A registers via the CUnet interface.

This chapter first explains how to access the CUnet interface and its registers, and then describes the registers inside MKY44-MC01A.

This chapter is designed to target readers who already have an understanding of CUnet. For the details of CUnet, refer to the related manuals. Since the internal structure of CUnet is fundamentally little endian, the internal structure and data structure of MKY44-MC01A are also little endian.

2.1 How to Access CUnet Interface and Registers

Figure 2.1 illustrates how to access the CUnet interface and its registers in order to use MKY44-MC01A. The Global Memory (GM) of CUnet is composed of 64 Memory Blocks (MB). One MB has 8 bytes.

MKY44-MC01A recognizes the MB that is set as DOSA as TMC (area To Motion Controller). This TMC is the area in which the user application operating MKY44-MC01A writes the data.

MKY44-MC01A recognizes the MB that is set as SA as FMC (area From Motion Controller). This FMC is the area in which MKY44-MC01A writes the data that is referenced by the user application.

Global memory composed of 64 memory blocks

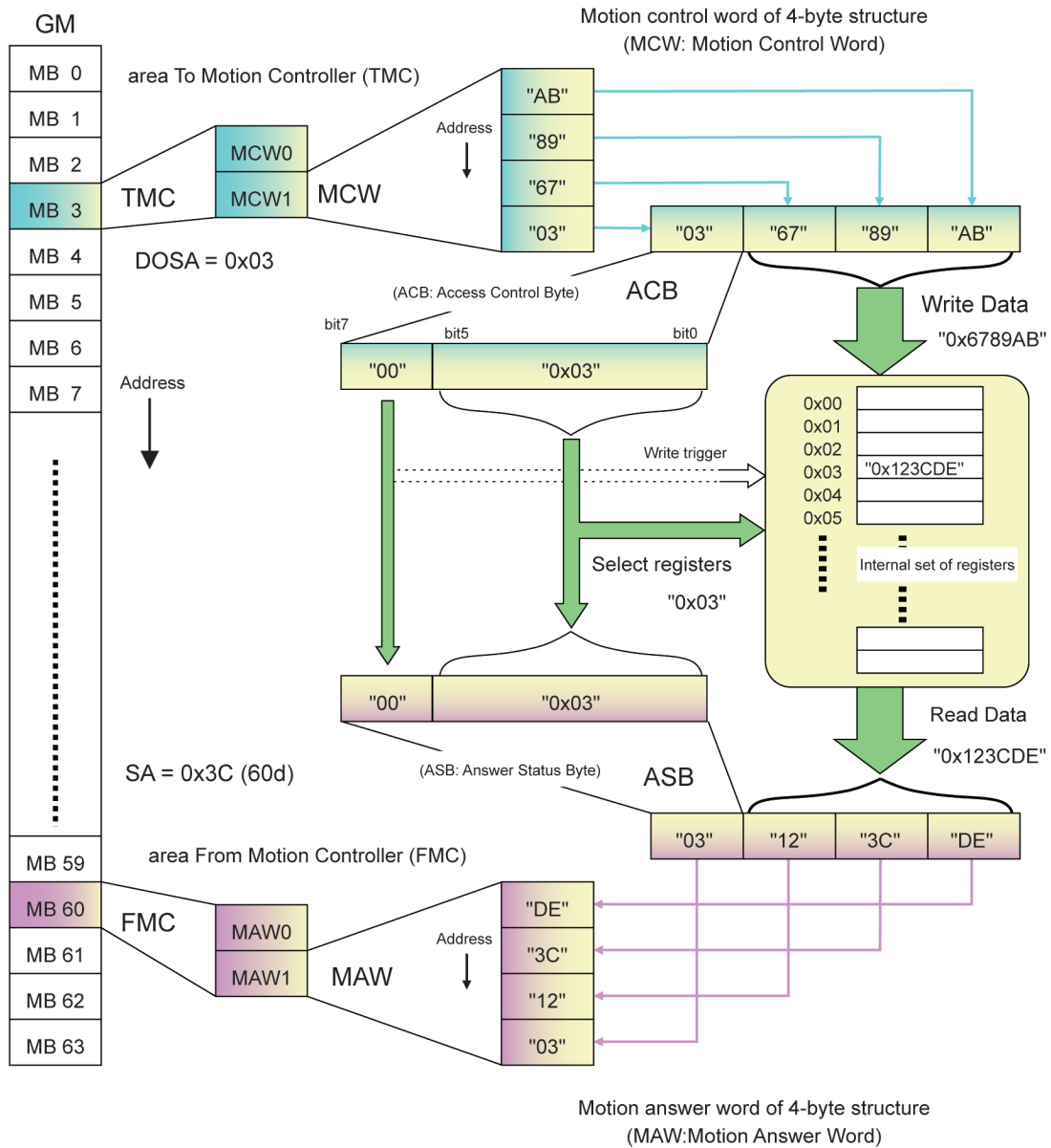

Fig. 2.1 CUnet I/F Image

2.1.1 How to Read Registers

One TMC (area To Motion-Control) is composed of two Motion Control Words (MCW). An MCW is composed of a 1-byte Access Control Byte (ACB) and 3-byte Write Data.

One FMC (area From Motion-Control) is composed of two Motion Answer Words (MAW).

An MAW is composed of a 1-byte Answer Status Byte (ASB) and 3-byte Read Data .

Figure 2.1 shows a state in which the user application sets the data “ACB = 0x03 and Write Dat = 0x6789AB” in MCW1, one of the two MCWs (MCW0 and MCW1).

The register numbers to access are set in bits 0 to 5 of the ACB.

When the user application is to read the register, set the upper 2 bits of the ACB as “00”. Figure 2.1 shows the read of the register number “0x03”.

The data of the selected register is stored in the Read Data of the MAW. In Figure 2.1, “0x1234DE” is stored. The data of the ACB of the MCW is echoed back to the ASB of the MAW.

When the user application uses MCW0 for access, the answer comes from MAW0. When the user application uses MCW1 for access, the answer comes from MAW1. Figure 2.1 shows a state in which the user application uses MCW1 for access and the answer comes from MAW1.

The following summarizes the concept of the read method described above.

- (1) User application writes MCW to TMC.
- (2) User application reads MAW from FMC.
- (3) If ACB in the written MCW and ASB in the read MAW are different, repeat (2) to wait for an echo back.
- (4) If ACB and ASB are the same, adopt the Read Data in MAW.

The time until the ACB matches the ASB is the time required for read. MKY44-MC01A is positioned ahead of the network via CUnet from the user application’s point of view. Therefore, the sum of cycle time of CUnet, signal propagation time of the communication wire, and process time in MKY44-MC01A is considered the response time required for read.

The process time in MKY44-MC01A is from 300 μ s to 2 ms. The range of this time depends on the motion state. Since the signal propagation time of a 100 m communication wire is about 1 μ s, it can be ignored relative to the entire time. The cycle time of CUnet is approximately 102 μ s to 2.5 ms depending on the setting of user applications. Therefore, the estimated time required for read access response is approximately 400 μ s to 4.5 ms.

There are two MCWs and MAWs, enabling two accesses at the same time. The estimated time required for read access response is the same either when performing two accesses at the same time or when performing one access. Since the Write Data in MCW is not adopted for read, the value of Write Data does not really matter.

As for MB (Memory Block) allocating TMC and FMC, TMC is allocated in the lower address position in Figure 2.1. However, there will be no problem if FMC is allocated in the lower address position.

2.1.2 How to Write to Registers

The way to write data to the registers of MKY44-MC01A shares the same concept as read in the previous section. However, the handling of the upper 2 bits of the ACB (Access Control Byte) set in the MCW (Motion Control Word) is different.

The following describes how to write to a register using Figure 2.2.

MKY44-MC01A recognizes the timing when the upper 2 bits of the ACB transition to a value other than “00” as the write trigger.

Specifically, the write trigger is when any of the following transitions of the upper 2 bits of the ACB occur: “00 ⇒ 01”, “00 ⇒ 10”, “00 ⇒ 11”, “01 ⇒ 10”, “01 ⇒ 11”, “10 ⇒ 01”, “10 ⇒ 11”, “11 ⇒ 01”, or “11 ⇒ 10”.

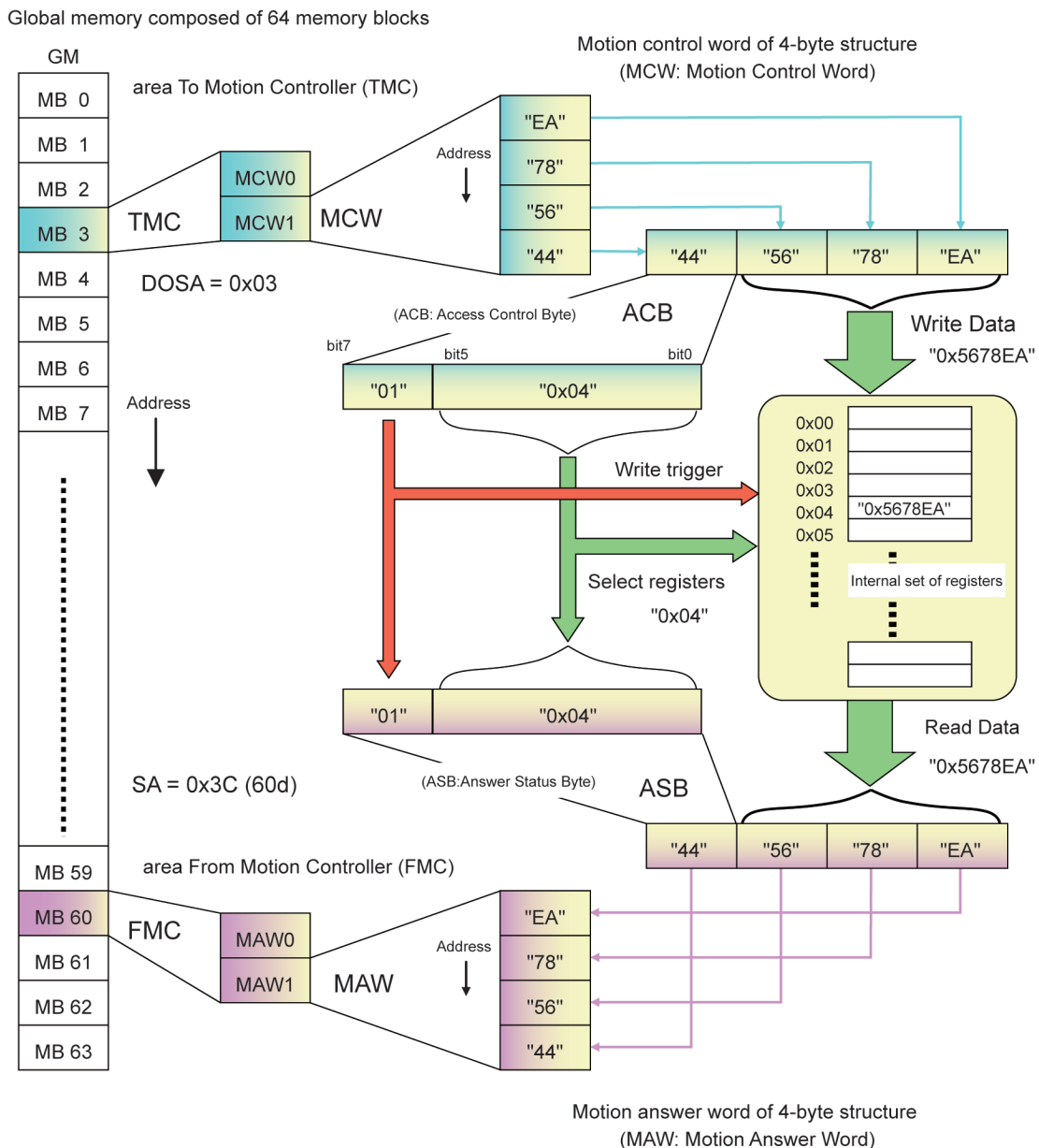

Fig. 2.2 How to Write

Once MKY44-MC01A recognizes a write trigger, it will write the Write Data in the MCW (Motion Control Word) to the register shown by the lower 6 bits of the ACB (Access Control Byte). In Figure 2.2, the Write Data “0x5678EA” is written in register number “0x04”.

Inside MKY44-MC01A, the register data selected by bits 0 to 5 of the ACB is set in Read Data, and the value copying the ACB is set in the ASB (Answer Status Byte) just like read operation. In this case, the data newly written in the register will be shown to the Read Data.

The MAW (Motion Answer Word) which is made up of ASB and Read Data is stored in MAW1 of the answer position for MCW1. Figure 2.2 shows the state in which the MAW of “ASB = 0x44 and Read Data = 0x5678EA” is stored in MAW1.

Therefore, the ACB in the MCW matches the ASB in the MAW when MKY44-MC01A completes the write process. Thus, the user application can confirm by an echo back that the instructed write in the register is successfully completed.

The following summarizes the concept of the write method described above.

- (1) User application writes MCW to TMC.
- (2) User application reads MAW from FMC.
- (3) If ACB in the written MCW and ASB in the read MAW are different, repeat (2) to wait for an echo back.
- (4) If ACB and ASB are the same, write operation will be completed.

The time until the ACB matches the ASB is the time required for write; it is the same as when in read.

As for the MBs (Memory Blocks) allocating TMC and FMC, there is no problem if FMC is allocated in the lower address position as when in read. There are two MCWs and MAWs, enabling two accesses at the same time.

If write is disabled in some bits in the register or if register size is less than 24 bits, Write Data and Read Data may differ. Therefore, determine write completion not by the match of the MCW and MAW but by the match of the ACB and ASB.

2.1.3 Cautions in Write Operation

MKY44-MC01A writes when the upper 2 bits of the ACB transition to a value other than “00”. Therefore, set the ACB at the same time as storing Write Data, or after storing Write Data. Also, do not allow the ACB to transition to other data until write process completion by the MAW in MKY44-MC01A is confirmed.

2.1.4 Cautions in Read Operation

MKY44-MC01A constantly reads out the latest data of the register selected by the lower 5 bits of the ACB (Access Control Byte) and then updates them to the MAW (Motion Answer Word) (see Figure 2.1).

CUnet is a real time data sharing tool that constantly repeats cycles in each fixed cycle time. Therefore, user applications can constantly monitor a specified register just by continuing to read the MAW of MKY44-MC01A.

However, it requires attention when the register data to read is a value that exceeds the byte limit and the register always has a possibility of transition. In MKY44-MC01A, this case applies to the registers of “Logical Position Coordinates (LPC)”, “Physical Position Coordinates (PPC)”, and “Now Speed (NS)”.

To read these data from FMC (area From Motion Controller) of CUnet’s Global Memory (GM), read them according to the following any one workaround plan to prevent read data hazard.

- (1) Read FMC (area From Motion Controller) using the hazard prevention function of the CUnet-dedicated LSI that is installed in the device to execute a user application program.
- (2) Read the MAW twice and adopt the matched data.
However, with this method, if both reads are executed within the cycle time of CUnet, the data may not match. Please confirm whether the user application is suitable before executing it.
- (3) Before the read, examine the progress status of CUnet’s cycle time to recognize the timing when data updates of FMC (area From Motion Controller) do not occur.

For more information about data hazards and (1) and (3) above, refer to the manual for the CUnet-dedicated LSI mounted in the device to execute a user application program.

For more information about Logical Position Coordinates (LPC), see **“1.3 Move Instructions”**. For more information about Physical Position Coordinates (PPC), see **“1.5.5 Physical Position Coordinate”**. For more information about Now Speed (NS), see **“2.2.3.4 Description of Register NS”**.

2.1.5 Warnings and Notifications from MKY44-MC01A

Normally, there is a relationship of echo back between the MCW (Motion Control Word) and MAW (Motion Answer Word).

There are four exceptions to this, as follows.

- (1) **Reset warning**
- (2) **CUnet line return warning**
- (3) **Error notification**
- (4) **Stop notification (optional)**

The above exceptions occur even when a user application does not set ACB (Access Control Byte) to the MCW or when it is waiting for echo back after setting.

2.1.5.1 Reset Warning State and How to Cancel It

If MKY44-MC01A returns from reset state by power-on or hardware reset, MKY44-MC01A will set “0x3F” in the entire area of all MAWs. This notifies the user application that it has just returned from a rest. This is called “reset warning state”.

MKY44-MC01A maintains the reset warning state until the entire area of all MCWs becomes “0x3F”. If MKY44-MC01A recognizes that the entire area of all MCWs is set “0x3F”, it will set the ASB (Answer Status Byte) of all MAWs to “0x00” and transition to the state showing the AXS (Axis Status) register of AX0.

In this way, user applications using MKY44-MC01A needs to cancel the reset warning state when starting the system. Also, after canceling the reset warning state, the user applications can use MKY44-MC01A based on normal register access.



By filling in certain data in two MCWs, MKY44-MC01A can be reset from user applications. For details, see “2.6 Exceptional Operation”.

2.1.5.2 CUnet Line Return Warning and How to Cancel It

If a once opened CUnet line is disconnected and later recovers, MKY44-MC01A will set the entire area of all MAWs (Motion Answer Words) to “0x3E” and indicate the recovery of the line. This is called the “CUnet line return warning state”.

This state occurs only when all the memory sharing targets cease to exist from the viewpoint of MKY44-MC01A: that is, upon return after CUnet says “Station Not Found”. For example, it will occur if only the communication line of MKY44-MC01A is disconnected and later connected again (e.g. in hot swap) when three or more CUnet devices are operating normally.

MKY44-MC01A maintains the CUnet line return warning state until the entire area of all MCWs becomes “0x3E”. If MKY44-MC01A recognizes that the entire area of all MCWs is set “0x3E”, it will set the ASB (Answer Status Byte) of all MAWs to “0x00” and transition to the state showing the AXS (Axis Status) register of AX0.



If disconnection of the CUnet line and reset of MKY44-MC01A occur simultaneously, only a reset warning will be issued.

2.1.5.3 Error Notification

If an error comes from receiving an operation instruction from user application, MKY44-MC01A will set “0x3D” in the ASB (Answer Status Byte) of the MAW that is targeted for echo back. Then, it will report an error to the user application. This is called the “error notification state”.

The contents of an error will be shown in the most significant byte of Read Data by the code. The lower two bytes left in Read Data will be shown as “0x00”.

MKY44-MC01A maintains the error notification state until the ACB (Access Control Byte) of the MCW becomes “0x3D”. If MKY44-MC01A recognizes that the ACB is set as “0x3D”, it will set “0x00” in the ASB (Answer Status Byte) of the MAW reporting the error and will transition to the normal state showing the AXS (Axis Status) register of AX0.



For the meanings of specific errors, see “[2.4 Errors and Error Notification](#)”.



The error notification state is reflected in MAWs that are targeted for echo back. So, an error from a command from MCW0 occurs in MAW0 and an error from a command from MCW1 occurs in MAW1.

2.1.5.4 Stop Notification (Optional)

If the option to report stop is selected in the SN (Stop Notification) bit of the PG2 (Property Group 2) register, it will report a stop to the user application by setting “0x3C” in the ASB (Answer Status Byte) of the MAW (Motion Answer Word) when the operating axis stops. This is called the “stop notification state”.

The stop notification of axis AX0 is reflected in MAW0. The stop factor in this case is shown as the motion event (ME) codes of “0x10 to 0x1F” to the most significant byte of Read Data. The lower two bytes left in Read Data will be shown as “0x00”. For more information on motion event codes, see **“2.5 Motion Events”**.

MKY44-MC01A maintains the stop notification state until the ACB (Access Control Byte) of MCW (Motion Control Word) becomes “0x3C”. In user applications, it is recommended to cancel the “stop notification state” after recognizing the stop notification.

MKY44-MC01A will set “0x00” in the ASB (Answer Status Byte) of the MAW issuing notification and will transition to the normal state showing the AXS (Axis Status) register of AX0.

2.1.5.5 Cautions for Warnings and Notifications

For user applications, it is difficult to identify the timing of the occurrence of reset warning state, CUnet line return warning state, and stop notification state. Therefore, it is recommended to adopt an algorithm that can address warnings and notifications by regularly checking the ASB of the MAW even while not issuing any instructions to MKY44-MC01A.

Also, you may receive warnings and notifications from MKY44-MC01A even while waiting for echo back after setting the ACB to the MCW so that user application can access the registers. Therefore, you need to adjust the basic procedure described in **“2.1.1 How to Read Registers”** and **“2.1.2 How to Write to Registers”** as (3) that says:

- (3) If ACB in the written MCW and ASB in the read MAW are different, repeat (2) to wait for an echo back.

To address the user application, adjust the procedure as follows:

- (3) If ACB in the written MCW and ASB in the read MAW are different, repeat (2) to wait for an echo back. If ASB of MAW shows an error or a warning, stop the access underway and transition to processes for recovering from an error or releasing a notification such as suitable for the user application.

2.1.6 Extended CUnet Interface (Optional)

Global memory composed of 64 memory blocks

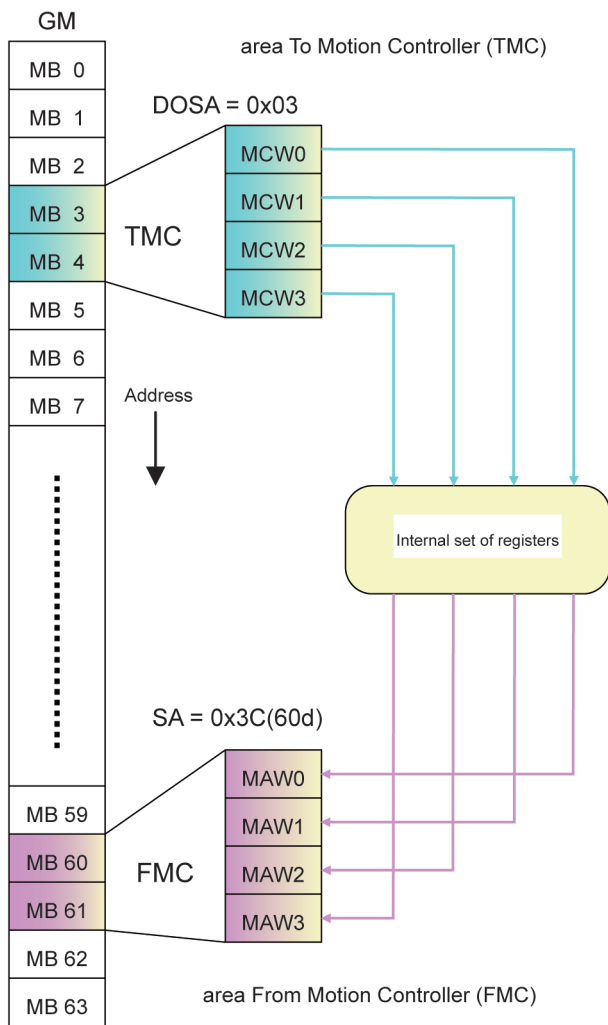

Fig. 2.3 Extended Interface

In the normal MKY44-MC01A, the CUnet interface is composed of a TMC (area To Motion Controller) of one memory block size and a FMC (area From Motion Controller) of one memory block size. It can use two sets of a MCW (Motion Control Word) and a MAW (Motion Answer Word).

MKY44-MC01A can extend its TMC (area To Motion Controller) and FMC (area From Motion Controller) to the size of two memory blocks (see Figure 2.3). This is done by setting HOPT0 (Hardware OPTion 0) to ON.

In this case, MKY44-MC01A refers to two memory blocks, one selected by DOSA and one right after it, to receive data from network. Also, MKY44-MC01A occupies two memory blocks, one selected by SA and one right after it.

The user application can simultaneously perform four sets of access: MCW0 ↔ MAW0, MCW1 ↔ MAW1, MCW2 ↔ MAW2, and MCW3 ↔ MAW3. The estimated time required for the read resulting from CUnet characteristics is the same whether you perform four accesses at the same time or only one.

The user application using MKY44-MC01A can use these four sets specialized, as in the example below.

Example:

MCW0 ↔ MAW0 for AX0 operation

MCW1 ↔ MAW1 for monitoring logical position coordinates

MCW2 ↔ MAW2 for monitoring the speed

MCW3 ↔ MAW3 for monitoring general-purpose input and operating general-purpose output

2.1.7 Processing Order of Access

MKY44-MC01A processes the accesses by the MCW (Motion Control Word) and MAW (Motion Answer Word) starting from lower addresses. For example, if there is a instruction specifying the target coordinate as “5000” in MCW0 and there is a operation start instruction to the target coordinate in MCW1, MKY44-MC01A will start toward the coordinate of “5000”.

Conversely, if there is a operation start instruction to the target coordinate in MCW0 and there is a instruction specifying the target coordinate as “5000” in MCW1, MKY44-MC01A will start toward the previously set coordinate. Then, it will update the register of the target coordinate to “5000” in preparation for next start. In this manner, the former and the latter are different in their intentions of instructions for axis operation.

Also, if “**2.1.6 Extended CUnet Interface (Optional)**” is selected, access from the MCW and MAW are processed starting from the lower address: MCW0 \leftrightarrow MAW0, MCW1 \leftrightarrow MAW1, MCW2 \leftrightarrow MAW2, and MCW3 \leftrightarrow MAW3.

2.1.8 Warnings of Setting Mistakes of SA and DOSA

If the SA value and DOSA value set in MKY44-MC01A by the hardware are the same, MKY44-MC01A cannot fulfill its function. Likewise, if the interface extension option (HOPT0) is specified, it cannot function in the following settings.

- (1) SA value and DOSA value are the same.
- (2) SA value is “0x3F”, the final position.
- (3) DOSA value is “0x3F”, the final position.
- (4) The position of SA value and SA value + 1 is set differently from the position of DOSA value and DOSA value + 1 value.

In the above cases, MKY44-MC01A warns that it is a setting mistake, putting the MCARE LED into a lighted state that continues from when returning from hardware reset. For more information about the MCARE LED, see “**3.5.2 Connection and Displayed States of LED Indicator Pins**”.

2.2 Internal Registers of MKY44-MC01A

In MKY44-MC01A, there are 16 registers for motion control and some registers not related to axis control. MKY44-MC01A is accessed by specifying a number “0 to 63 (0 to 0x3F)” (see Figure 2.4).

AX0			
Number	Abbreviation	Name	Target function/main usage
0x00	AXS	AXis Status	Axis status
0x01	LPC	Logical Position Coordinates	Logical position coordinate
0x02	PPC	Physical Position Coordinates	Physical position coordinate
0x03	NS	Now Speed	Current speed
0x04	COM	COMmand	Registers to execute instructions to axes
0x05	TPC	Target Position Coordinates	Target position coordinate
0x06	RAD	Relative / Absolute Distance	Distance
0x07	LS	Lower Speed	Lower speed
0x08	US	Upper Speed	Upper speed
0x09	ACC	ACCeleration	Acceleration
0x0A	SCom	Synchronization Command	Register to set synchronization instruction to axes
0x0B	STS	Synchronization Trigger Setup	Register to set conditions for synchronization trigger
0x0C	PLC	Plus Limit Coordinates	Registers to set limit coordinates
0x0D	MLC	Minus Limit Coordinates	
0x0E	PG1	Property Group 1	Registers to set Do3 watchdog timer value, speed range, acceleration curve, Peak Keep Time, and options
0x0F	PG2	Property Group 2	

Number	Abbreviation	Name	Target function/main usage
0x10 to 0x13	M.R.	Maker Reserved	Area reserved by manufacturer. Do not access.
0x14	P2C	Port 2 Control	Controls general-purpose I/O of pins Do20 to Do23 and #Di20 to #Di23.
0x15 to 0x1E	M.R.	Maker Reserved	Area reserved by manufacturer. Do not access.
0x1F	P2I	Port2 Invert	Logical inversion settings of pins Do20 to Do23 and #Di20 to #Di23.

0x20	WA	Write Assist	Assists with initialization of registers and write to registers that cannot be written to directly.
0x21 to 0x24	CC	Chip Code	Read as “MKY44MC01Ann”, the chip code and version number.
0x25 to 0x3B	M.R.	Maker Reserved	Area reserved by manufacturer. Do not access.
0x3C to 0x3F	SysU	System Use	Perform system-scale operations such as reset, communication line disconnection, and error setting and release.

Fig. 2.4 Register Numbers and Registers

2.2.1 Register Structure of Motion Control and Port 2 Control

Figure 2.5 shows the registers for motion control and the register structure of Port 2 control.

W.P.	Abbreviation	Target function	bit																				
			23	22	21	20	19	18	17	16	15	14	13	12	11	10	9	8	7	6	5	4	3
	AXS	Axis status	*1 AXS																				
✓	LPC	Logical position coordinates	-8,388,608 to +8,388,607 (0x800000 to 0x7FFFFFFF)																				
✓	PPC	Physical position coordinates	-8,388,608 to +8,388,607 (0x800000 to 0x7FFFFFFF)																				
✓	NS	Now speed											0 to 24,000 (0x5DC0)										
	COM	Instruction to axis	*2 COM																				
	TPC	Target position coordinates	-8,388,608 to +8,388,607 (0x800000 to 0x7FFFFFFF)																				
	RAD	Distance	-8,388,608 to +8,388,607/0 to 16,777,215 (0xFFFFFFFF)																				
	LS	Lower speed											10 to 24,000 (0x000A to 0x5DC0)										
	US	Upper speed											10 to 24,000 (0x000A to 0x5DC0)										
	ACC	Acceleration	Down Rate (DR)										Up Rate (UR)										
	SCom	Synchronization instruction to axis	*3 SCom																				
✓	STS	Synchronization trigger											STA : 0 to 0x1FF					STD : 0 to 0xFF					
✓	PLC	Plus limit coordinates	-8,388,608 to +8,388,607 (0x800000 to 0x7FFFFFFF)																				
✓	MLC	Minus limit coordinates	-8,388,608 to +8,388,607 (0x800000 to 0x7FFFFFFF)																				
✓	PG1	Property Group 1	*4 PG1																				
✓	PG2	Property Group 2	Option selection bit																				
	P2C	Port 2 control	P2C										OP2 0 to 0xF					IP2M 0 to 0xF					
✓	P2I	Port 2 logical invert											OP2I 0 to 0xF					IP2I 0 to 0xF					

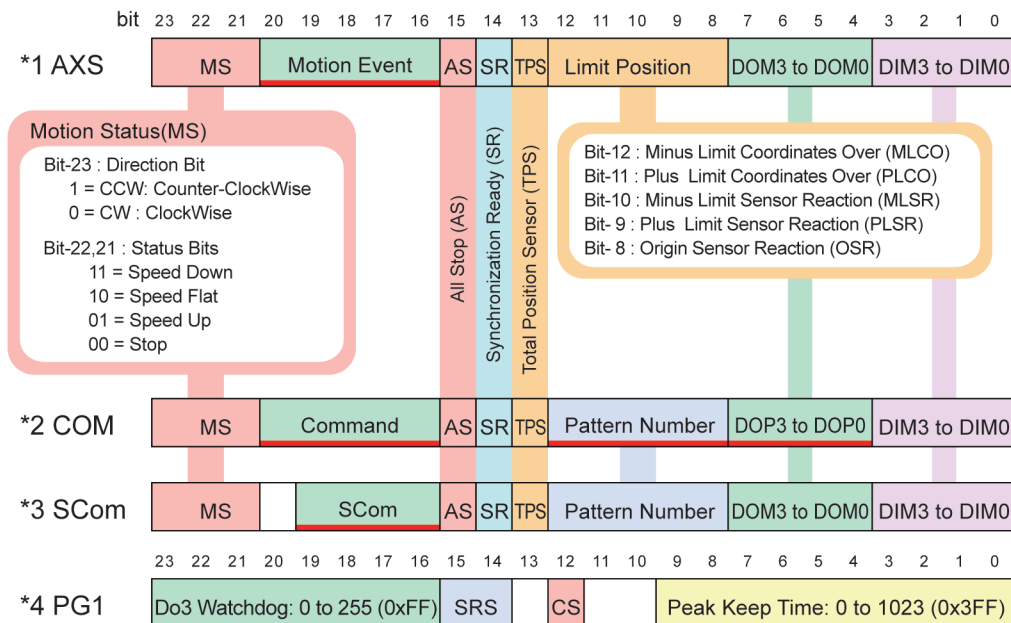

Bits that can be written directly W.P. Write-protected registers or read only registers

Fig. 2.5 Register Structure of Motion Control and Port 2 Control

2.2.2 Write-Protected Registers

Registers TPC, RAD, LS, US, and ACC, which set directly necessary parameters for axis operation, can have values written directly using the method described in **“2.1.2 How to Write to Registers”**. These values are referenced in MKY44-MC01A when operation instructions are given to the axis.

Registers COM and SCom, which give instructions to the axis, register AXS, which clears the reference values of their status, and register P2C, which controls Port 2, can be also written directly using the method described in **“2.1.2 How to Write to Registers”**.

Registers STS, PLC, MLC, PG1, PG2, and P2I cannot be changed during axis operation. Also, the values of registers LPC and PPC cannot be changed except in initialization setting and coordinate transition. Therefore, these registers are write-protected so that they cannot be written directly using the method described in **“2.1.2 How to Write to Registers”**.

To set data in these registers, first write the data in register WA (Write Assist) of register number “0x20”. Then, set the required data using commands. For more information about these commands, see **“2.3 Commands of MKY44-MC01A”** and **“2.3.3 Data Setting Commands for Write-Protected Registers”**.

For more information about writing to register P2I, see **“2.2.3.16 Description of Register P2I”**.

2.2.3 Descriptions of Registers for Motion Control

This section describes the registers for motion control.

2.2.3.1 Description of Register AXS

Register AXS (AXis Status) shows status of the axis (see Figure 2.5). Clear (“0x00”) can be written only in ME (Motion Event), showing events of axis operation start or stop. The others are read only bits that show axis status (see Table 2-1).

Table 2-1 Description of AXS

Bit	Abbreviation	Item	Description	Reference
23 to 21	MS	Motion Status	Bit 23: Rotation direction “1”: Minus (CCW: Counter-ClockWise) “0”: Plus (CW: ClockWise) Bit 22, 21: Status “11”: Deceleration (Speed Down) “10”: Constant speed (Speed Flat) “01”: Acceleration (Speed Up) “00”: Stop (Stop)	The same data as registers COM and SCom
20 to 16	ME	Motion Event	Show events like axis operation start or stop. Only clear (“0x00”) can be written.	2.5 Motion Events
15	AS	All Stop	Shows the status of the all stop input pin [0:non, 1:Reaction]	1.5 Stop Functions
14	SR	Synchronization Ready	Shows “1” when synchronization command preparation is completed (synchronization trigger wait state)	1.7 Synchronization of Operation Instructions
13	TPS	Total Position Sensor	Shows “1” when any bit of LP in register AXS is “1”.	1.5 Stop Functions
12 to 8	LP	Limit Position	Show the status of limit or origin sensors. Bit 12: Minus limit coordinate [0: non, 1: Over] Bit 11: Plus limit coordinate [0: non, 1: Over] Bit 10: Minus hardware limit [0: non, 1: Reaction] Bit 9: Plus hardware limit [0: non, 1: Reaction] Bit 8: Origin sensor [0: non, 1: Reaction]	1.5 Stop Functions
7 to 4	DOM3 to DOM0	Data Out port Monitor	Show the status of general-purpose output pins	1.9.2 General-Purpose Input Pins/General-Purpose Output Pins
3 to 0	DIM3 to DIM0	Data In port Monitor	Show the status of general-purpose input pins	1.9.2 General-Purpose Input Pins/General-Purpose Output Pins

User applications can understand the current motion status by referring to MS (Motion Status).

In the AS (All Stop) bit, “1” is shown when the all stop input pin is active: “Lo”.

In the SR (Synchronization Ready) bit, “1” is shown when receiving a synchronization trigger after completing synchronization command preparation. If any status of limit and origin sensors in bits 12 to 8 of this register is active, “1” will be shown in TPS (Total Position Sensor) bit.

MS, AS, SR, TPS, DOM3 to DOM0, and DIM3 to DIM0 have the same data as registers COM and SCom.

2.2.3.2 Description of Register LPC

Register LPC (Logical Position Coordinates) is a 24-bit-width register showing the logical position coordinates (see Figure 2.5).

For more information on logical position coordinates, see **“1.3 Move Instructions”**. In the initialization of this register, the data shown by register WA can be written by with the LPCwrite instruction only when the axis is stopped. For more information on the LPCwrite instruction, see **“2.3 Commands of MKY44-MC01A”**.

2.2.3.3 Description of Register PPC

Register PPC (Physical Position Coordinates) is a 24-bit-width register showing the physical position coordinates (see Figure 2.5).

For more information on physical position coordinates, see **“1.5.5 Physical Position Coordinate”**. In the initialization of this register, the data shown by register WA can be written with the PPCwrite instruction only when the axis is stopped. For more information on the PPCwrite instruction, see **“2.3 Commands of MKY44-MC01A”**.

2.2.3.4 Description of Register NS

Register NS (Now Speed) is a 15-bit-width register showing the speed when the axis is operating (see Figure 2.5). The speed values to be expressed are “0 to 24,000 (0x0000 to 0x5DC0) pps”. When the axis is stopped, “0 (0x0000)” is shown. This register is read only. In the upper reserved bits (bits 23 to 15), “0” is shown.

2.2.3.5 Description of Register COM

Register COM (Command) is a register to instruct the axis (see Figure 2.5). For details on instructions, see “**2.3 Commands of MKY44-MC01A**”.

This register also specifies pattern numbers to operate pattern memories and sets data to output to the general-purpose Do pins. Regarding the operation of pattern memory, see “**2.3.4 Operation Commands of Pattern Memory**”. Regarding writing data to output to general-purpose output pins, see “**2.3.2 Commands to Set Data in General-Purpose Output Pins**”.

The bits other than Command, Pattern Number and DOP3 to DOP0 are read only bits that show axis status (see Table 2-2). MS, AS, SR, TPS, and DIM3 to DIM0 have the same data as registers AXS and SCom.

Table 2-2 Description of COM

Bit	Abbreviation	Item	Description	Reference
23 to 21	MS	Motion Status	Bit 23: Rotation direction “1”: Minus (CCW: Counter-ClockWise) “0”: Plus (CW: ClockWise) Bit 22, 21: Status “11”: Deceleration (Speed Down) “10”: Constant speed (Speed Flat) “01”: Acceleration (Speed Up) “00”: Stop (Stop)	The same data as registers AXM and SCom.
20 to 16	COM	Command	Bits to write instructions.	2.3 Commands of MKY44-MC01A
15	AS	All Stop	Shows status of all stop input pin. [0:non, 1: Reaction]	1.5 Stop Functions
14	SR	Synchronization Ready	Shows “1” when synchronization command preparation is completed (synchronization trigger wait state).	1.7 Synchronization of Operation Instructions
13	TPS	Total Position Sensor	Shows “1” when any bit of LP in register AXS is “1”.	1.5 Stop Functions
12 to 8	PN	Pattern Number	Bits to write the pattern number of the target to operate pattern memory.	1.6 Pattern Memory and File
7 to 4	DOP3 to DOP0	Data Out Port	Bits to write general-purpose output data.	1.9.2 General-Purpose Input Pins/General-Purpose Output Pins 2.3.2 Commands to Set Data in General-Purpose Output Pins
3 to 0	DIM3 to DIM0	Data In port Monitor	Show the status of general-purpose input pins.	1.9.2 General-Purpose Input Pins/General-Purpose Output Pins

2.2.3.6 Description of Register TPC

Register TPC (Target Position Coordinates) is a 24-bit-width register that specifies the target position coordinates to issue move instructions specifying target (see Figure 2.5). The coordinate values of “-8,388,608 to 8,388,607 (0x800000 to 0x7FFFFFFF)” can be written into this register. For more information on target position coordinates, see “**1.3.2 Move Instruction to Specify Target**”.

If the ASE (Auto Start Enable) bit of the PG2 (Property Group 2) register is set to “1” in advance, a stopped axis will start operating right after the value is written into this register (even if the operation start command is not issued to the COM register) because it is considered that the “TP_Pattern” command is executed (see “**1.3.9 Usage Specifying Only Distance**”).

In such a case, by setting “1” in the PAC (Parameter Auto Correction) bit and RS (Reduction Select) bit of the PG2 register, axis operation can avoid errors and warnings even when there are errors in parameter values or when there is only a short distance to the target position coordinate.



In usage specifying only distance, a stopped axis can start operation without issuing operation commands to register COM. Please make such use only when there will be no danger from starting axis operation.

2.2.3.7 Description of Register RAD

Register RAD (Relative/Absolute Distance) is a 24-bit-width register to specify distance (see Figure 2.5).

This register is referred to when move instructions are issued to specify distance. To this register, you can write the values of “RD (Relative Distance): -8,388,608 to 8,388,607 (0x800000 to 0x7FFFFFFF)” or “AD (Absolute Distance): 0 to 16,777,215 (0x000000 to 0xFFFFFFFF)”. When receiving a move instruction to specify distance, MKY44-MC01A determines whether to interpret the value of this register as relative distance or absolute distance by using the RADS (Relative/Absolute Distance Select) bit of the PG2 register. For more information on relative distance and absolute distance, see “**1.3.1 Move Instruction to Specify Distance**”.

If the ASE (Auto Start Enable) bit of the PG2 register is set to “1” in advance, a stopped axis will start operating right after the value is written into this register (even if the operation start command is not issued to the COM register) because it is considered that the “DS_Pattern” command is executed (see “**1.3.9 Usage Specifying Only Distance**”).

In such a case, by setting “1” in the PAC bit and RS bit of the PG2 register, axis operation can avoid errors and warnings even when there are errors in parameter values or when there is only a short distance to the target position coordinate.



In “**1.3.9 Usage Specifying Only Distance**”, a stopped axis can start operation without issuing operation commands to register COM. Please make such use only when there will be no danger from starting axis operation.

2.2.3.8 Descriptions of Registers LS and US

Register LS (Lower Speed) and US (Upper Speed) are 15-bit-width registers to specify speed. The upper reserved bits (bits 23 to 15) are “0” (see Figure 2.5). Although the values “0x0000 to 0x7FFF” can be written to these registers, the valid values depend on the speed range. For details on speed, see **“1.2.2 Settable Speed”**.

The values of these registers can be changed at any time. However, only if the axis is operating when the STS (Stop Type Select) bit of the PG2 (Property Group 2) register is “1”, the LS register will be write-protected and cannot be changed. This will guarantee operation when deceleration stop is suddenly issued by a limit sensor or such.

When a command controlling axis operation is issued, MKY44-MC01A examines the values of registers LS and US and whether their speed transition width is within the valid range, as needed. When they are out of the valid range and have harmful effects, it will continue operation after automatically changing the setting to a value within the valid range, if the setting of the PAC (Parameter Auto Correction) bit of the PG2 register is “1” (see **“1.2.5 Parameter Auto Correction Function”**). If the PAC bit of the PG2 register is “0”, it will issue an error or a warning and stop command execution.

2.2.3.9 Description of Register ACC

Set plus acceleration (UR: Up Rate) to the lower 12 bits and set minus acceleration (DR: Down Rate) to the upper 12 bits of the ACC (ACCEleration) register (see Figure 2.5). For the UR and DR of this register, values of rate format or required time format can be written.

When receiving an operation instruction of the axis, MKY44-MC01A determines whether to interpret the value of this register as a rate or a required time by using the ARTS (Acceleration Rate/Time Select) bit of the PG2 register. For more information about acceleration in rate format, see **“1.2.3 Setting Acceleration (Rate Format)”**. For more information about acceleration in required time format, see **“1.2.4 Setting Acceleration (Required Time Format)”**.

The value of this register can be changed at any time. However, only if the axis is operating when the STS (Stop Type Select) bit of the PG2 (Property Group 2) register is “1”, the ACC register will be write-protected and cannot be changed. This will guarantee operation when deceleration stop is suddenly issued by a limit sensor or such.

The value of this register will be checked when MKY44-MC01A receives an axis operation instruction. If the check result is not appropriate, an error will occur. This register is subject to the parameter auto correction function. By selecting the parameter auto correction function, you can avoid or reduce errors in this register setting. For details on the parameter auto correction function, see **“1.2.5 Parameter Auto Correction Function”**.

2.2.3.10 Description of Register SCom

Register SCom (Synchronization Command) sets synchronization commands (see Figure 2.5).

The command to synchronize is written in the SCom bits. When synchronization becomes ready, SR (Synchronization Ready) has “1”. For the details of synchronization instructions (SCom), see “**2.3.5 Synchronization Commands**”. Other bits are read only (Table 2-3). MS, AS, SR, TPS, DOM3 to DOM0, and DIM3 to DIM0 have the same data as registers AXS and COM. PN is the same as register COM.

Table 2-3 Description of SCom

Bit	Abbreviation	Item	Description	Reference
23 to 21	MS	Motion Status	Bit 23: Rotation direction “1”: Minus (CCW: Counter-Clock Wise) “0”: Plus (CW: Clock Wise) Bit 22, 21: Status “11”: Deceleration (Speed Down) “10”: Constant speed (Speed Flat) “01”: Acceleration (Speed Up) “00”: Stop (Stop)	The same data as registers AXS and COM
20	---	---	Reserved bit. “0” is shown	
19 to 16	Scom	Synchronization Command	Bits to write instructions to synchronize	1.7 Synchronization of Operation Instructions 2.3.5 Synchronization Commands
15	AS	All Stop	Shows status of all stop input pin. [0:non, 1: Reaction]	1.5 Stop Functions
14	SR	Synchronization Ready	Shows “1” when synchronization command preparation is completed (synchronization trigger wait state)	1.7 Synchronization of Operation Instructions
13	TPS	Total Position Sensor	Shows “1” when any bit of LP in register AXS is “1”	1.5 Stop Functions
12 to 8	PN	Pattern Number	Bits to show the pattern number of the operation target	1.6 Pattern Memory and File
7 to 4	DOM3 to DOM0	Data Out port Monitor	Show the status of general-purpose output pins	1.9.2 General-Purpose Input Pins/General-Purpose Output Pins
3 to 0	DIM3 to DIM0	Data In port Monitor	Show the status of general-purpose input pins	1.9.2 General-Purpose Input Pins/General-Purpose Output Pins

2.2.3.11 Description of Register STS

Register STS (Synchronization Trigger Setup) sets the trigger conditions of “shared data synchronization” (see Figure 2.5). Set the data for the synchronization trigger in the lower 8 bits of STD (Synchronization Trigger Data) and set the address (0x000 to 0x1FF) for the synchronization trigger in the register (bits 8 to 16) of STA (Synchronization Trigger Address). In the upper reserved bits (bits 23 to 17), “0” is shown. The synchronization trigger has the address in which the head of Global Memory (GM), CUnet’s shared memory, is “0x000”. For details on synchronization triggers, see “**1.7 Synchronization of Operation Instructions**”.

This register is write-protected. The STSwrite instruction can write the data stored in register WA to register STS. For this register, as long as the axis is stopped, the STSwrite instruction will be received. Regarding the initialization of this register, see “**2.2.4 Initial Values of Registers**”. This register has no effect if “shared data synchronization” is not selected by the SyncT (Sync Type) bit of the PG2 (Property Group 2) register.

2.2.3.12 Description of Registers PLC and MLC

PLC (Plus Limit Coordinates) is a 24-bit-width register to set plus limit coordinates and MLC (Minus Limit Coordinates) is a 24-bit-width register to set minus limit coordinates. The coordinate values of “-8,388,608 to 8,388,607 (0x800000 to 0x7FFFFFF)” can be set in these registers (see Figure 2.5). For details on limit coordinates, see **“1.5.6 Stop Setting Using Limit Coordinates”**.

These registers are write-protected. These registers can set the data shown by register WA using the PLCwrite and MLCwrite instructions as long as the axis is stopped. Regarding the initialization of these registers, see **“2.2.4 Initial Values of Registers”**. These registers have no effect if stop by limit coordinates is not validly selected by the LCE (Limit Coordinates Enable) bit of the PG2 (Property Group 2) register. Also, the LCLPPP (Limit Coordinates LP/PP) bit of the PG2 register selects whether the values of these registers are compared to logical position coordinates (LPC) or physical position coordinates (PPC).

2.2.3.13 Description of Register PG1

Register PG1 (Property Group 1) can set Do3 Watchdog (Do3W), speed range (SRS: Speed Range Select), speed transition curve (CS: Curve Select), and Peak Keep Time (PKTS: Peak Keep Time Setup) for triangular drive prevention function (see Figure 2.5 and Table 2-4).

Table 2-4 Settings of PG1

Bit	Abbreviation	Setting item	Set value	Reference
23 to 16	Do3W	Do3 Watchdog	0 to 225 (0x00 to 0xFF) : “1” = 2.55 seconds (max: 10 minutes and 50 seconds)	1.9.4 Do3 Watchdog Timer Function
15, 14	SRS	Speed Range Select	“11”: 160 pps to 24 kpps “10”: 160 pps to 24 kpps “01”: 40 pps to 10.0 kpps “00”: 10 pps to 2.5 kpps	1.2.2 Settable Speed
13			Reserved bit. “0” is shown.	
12	CS	Curve Select	“0”: Straight line “1”: S-curve	1.2.6 Selecting Speed Transition Curve
11, 10			Reserved bit. “0” is shown.	
9 to 0	PKTS	Peak Keep Time Setup	0 to 1023 (0x000 to 0x3FF) “1” = 10 ms (max: 10.23 seconds)	1.2.11 Triangular Drive Prevention Function

If the value of Do3 Watchdog (Do3W) is set to “0x00”, pin Do3 will function as a normal general-purpose Do pin.

The state in which “0x000” is set in Peak Keep Time Setup (PKTS) is the OFF state of the triangular drive prevention function.

This register is write-protected. This register can set the data shown by register WA using the PG1write instruction as long as the axis is stopped. Generally, it is recommended to set the values of register PG1 in an initial stage such as system startup or operation start. Regarding the initialization of this register, see **“2.2.4 Initial Values of Registers”**. For the factory default setting values, see Table 2-5.

Table 2-5 Factory Default Settings of PG1

Bit	Abbreviation	Value
23 to 16	Do3W	0x00
15, 14	SRS	“10”
13	---	“0”
12	CS	“1”
11, 10	---	“00”
9 to 0	PKTS	0x000

24 bit Data = 0x009000

2.2.3.14 Description of Register PG2

Register PG2 (Property Group 2) can set various options (see Figure 2.5).

The Options corresponding to each bit of the PG2 register are shown in Table 2-6.

This register is write-protected. This register can set the value to the data shown by register WA using the PG2write instruction as long as the axis is stopped. Generally, it is recommended to set the values of register PG2 in an initial stage such as system startup or operation start. Regarding the initialization of this register, see “2.2.4 Initial Values of Registers”. For the factory default setting values, see Table 2-7.

Table 2-6 Settings of PG2

Bit	Abbreviation	Item/description	Setting	Reference
23	PAC	Parameter automatic correction function (Parameter Auto Correction)	0: OFF 1: ON	1.2.5 Parameter Auto Correction Function
22	PRE	Pattern reduction (Pattern Reduction Enable)	0: Disable 1: Enable	1.3.8 Pattern Reduction Function
21	SN	Stop notification function (Stop Notification)	0: OFF 1: ON	2.1.5.4 Stop Notification (Optional)
20	InvMD	Rotation direction signal logical invert (Invert Motion Direction)	0: Normal 1: Invert	1.9.5 Logical Inversion Function for Pins
19	InvPPD	Physical coordinate direction input logical invert (Invert Physical Pulse Direction)	0: Normal 1: Invert	1.9.5 Logical Inversion Function for Pins
18	ASE	Automatic start enable (Auto Start Enable)	0: Disable 1: Enable	1.3.9 Usage Specifying Only Distance
17	OSE	Overscale enable (OverScale Enable)	0: Disable 1: Enable	1.3.1 Move Instruction to Specify Distance
16	SCDo3	Do3 start condition (Start Condition with Do3)	0: Normal 1: with Do3	1.9.4 Do3 Watchdog Timer Function

Bit	Abbreviation	Item/description	Setting	Reference
15	STS	Stop type (Stop Type Select)	0: Stop immediately 1: Deceleration stop	1.5 Stop Functions
14	SyncT	Synchronization type selection (Sync Type)	0: Shared data synchronization 1: External signal synchronization	1.7.1 Synchronization Trigger
13	ARTS	Acceleration setting format selection (Acceleration Rate/Time Select)	0: Rate 1: Time	1.2.3 Setting Acceleration (Rate Format) 1.2.4 Setting Acceleration (Required Time Format)
12	RADS	Relative distance/absolute distance selection (Relative/Absolute Distance Select)	0: Relative 1: Absolute	1.3.1 Move Instruction to Specify Distance
11	Do012C	Do0 to Do2 output clear function (Do012 Clear)	0: OFF 1: ON	1.9.6 Addressing DONA and Network Failure
10	DONAS	DONA stop function (DONA Stop)	0: OFF 1: ON	1.5.1 All Stop 1.5.2 DONA Stop 1.9.6 Addressing DONA and Network Failure
9	LCLPPP	Limit coordinate comparison target (Limit Coordinates LP/PP)	0: LP (Logical Position) 1: PP (Physical Position)	1.5.6 Stop Setting Using Limit Coordinates
8	LCE	Limit coordinate stop (Limit Coordinates Enable)	0: Disable 1: Enable	1.5.6 Stop Setting Using Limit Coordinates

Table 2-6 Settings of PG2

Bit	Abbreviation	Item/description	Setting	Reference
7	m.r.	Reserved by manufacturer (Reserved bit)	Set to "0"	---
6				
5	Do2FS	Function selection of Do2 pin (Do2 Function select)	0: Normal 1: Motion Active signal	1.9.2 General-Purpose Input Pins/ General-Purpose Output Pins 1.9.3 Output Signal Indicating Axis Operating
4	InvDo3	Do3 output signal logical invert (Invert Do3)	0: Normal 1: Invert	1.9.2 General-Purpose Input Pins/ General-Purpose Output Pins 1.9.5 Logical Inversion Function for Pins
3	InvDo012	Do0 to Do2 output signal logical invert (Invert Do012)	0: Normal 1: Invert	1.9.2 General-Purpose Input Pins/ General-Purpose Output Pins 1.9.5 Logical Inversion Function for Pins
2	Di23FS	Function selection of Di2 and Di3 pins (Di2, 3 Function Select)	00: Di3, Di2 Normal 01: Stop sensor 10: Manual single 11: Manual continue	1.5.3 Stop Using Origin Sensor, EZ Sensor, and Stop Signal Input 1.8 Addressing Manual Operation 1.9.2 General-Purpose Input Pins/ General-Purpose Output Pins
1				
0	Di1FS	Function selection of Di1 pin (Di1 Function Select)	0: Di1 Normal 1: Stop signal input	1.5.3 Stop Using Origin Sensor, EZ Sensor, and Stop Signal Input 1.9.2 General-Purpose Input Pins/ General-Purpose Output Pins

Table 2-7 Factory Default Settings of PG2

Bit	Abbreviation	Value
23	PAC	1
22	PRE	1
21	SN	0
20	InvMD	0
19	InvPPD	0
18	ASE	0
17	OSE	0
16	SCDo3	0

8bit Data = 0xC0

Bit	Abbreviation	Value
15	STS	1
14	SyncT	0
13	ARTS	0
12	RADS	0
11	Do012C	0
10	DONAS	1
9	LCLPPP	0
8	LCE	1

8bit Data = 0x85

Bit	Abbreviation	Value
7	m.r.	0
6		0
5	Do2FS	0
4	InvDo3	0
3	InvDo012	0
2	Di23FS	0
1		0
0	Di1FS	0

8bit Data = 0x00

2.2.3.15 Description of Register P2C

Register P2C (Port 2 Control) controls pins Do20 to Do23 and #Di20 to #Di23 (see Table 2-8). Regarding the initialization of this register, see **"2.2.4 Initial Values of Registers"**.

To set the data in pins Do20 to Do23 of general-purpose output port 2, set the data to output to bits OP20 to OP23 of this register and set "0x12" in the P2C bits at the same time.

If the bit of the P2I register corresponding to each bit of the Do20 to Do23 pins is "0", Low level is output to a target pin with "0" in OP2, and High-level is output to a target pin with "1" in OP2.

To refer to the status of pins #Di20 to #Di23 of general-purpose port 2, read this register.

If the bit of the P2I register corresponding to each bit of the #Di20 to #Di23 pins is "0", the High-level of #Di20 to #Di23 pins is shown as "0" and the Low level is shown as "1" in bits IP2M0 to IP2M3.

Table 2-8 Description of P2C

Bit	Abbreviation	Item	Description
23 to 21	---	---	Reserved bit. "0" is shown.
20 to 16	P2C	Port 2 Control	To set data in pins Do20 to Do23, set "0x12" in this bit. To set logical inversion data in the P2I register, set "0x1C" in this bit.
15 to 8	---	---	Reserved bit. "0" is shown.
7 to 4	OP23 to OP20	Out Port 2	This is the bit to write the general-purpose output data of pins Do20 to Do23.
3 to 0	IP2M3 to IP2M0	In Port 2 Monitor	Show the status of general-purpose input pins #Di20 to #Di23.

2.2.3.16 Description of Register P2I

This P2I (Port 2 Invert) register can set logical inversion of the Do20 to Do23 pins and #Di20 to #Di23 pins handled by the P2C (Port 2 Control) register. The logic of a target bit whose register value is set to “1” will be inverted (see Table 2-9).

This register is write-protected. This register can set the value to the data shown by register WA as long as the axis is stopped. To set logical inversion data for a port in register P2I, right after writing the value to be set in register P2I in register WA, write “0x1C” in the PC2 bit of the P2C register (see Table 2-8). Generally, it is recommended to set the value of register P2I in an initial stage such as system startup or operation start. Regarding the initialization of this register, see “2.2.4 Initial Values of Registers”.

Table 2-9 Settings of P2I

Bit	Name	Target bit of P2C	Target pin
23 to 8	Reserved bits. “0” is shown.		
7	OP2I3	OP23	Do23
6	OP2I2	OP22	Do22
5	OP2I1	OP21	Do21
4	OP2I0	OP20	Do20
3	IP2I3	IP2M3	#Di23
2	IP2I2	IP2M2	#Di22
1	IP2I1	IP2M1	#Di21
0	IP2I0	IP2M0	#Di20

2.2.4 Initial Values of Registers

Table 2-10 shows the initial value of each register after returning from reset.

Table 2-10 Initial Value of Each Register after Returning from Reset

Abbreviation	Register name	Target	Initialization value
AXS	AXis Status	Motion event	“0x000000”
LPC	Logical Position Coordinates	Logical position coordinates	“0x000000”
PPC	Physical Position Coordinates	Physical position coordinates	“0x000000”
NS	Now Speed	Current speed	“0x000000”
COM	COMmand	Operation instruction Pattern Number General-purpose Do	“0x000000”
TPC	Target Position Coordinates	Target position coordinates	The data of pattern memory “No = 0” corresponding to the axis read from the flash ROM is set as the initial value.
RAD	Relative / Absolute Distance	Distance	
LS	Lower Speed	Lower speed	
US	Upper Speed	Upper speed	
ACC	ACCeleration	Acceleration	
SCom	Synchronization Command	Synchronization command	“0x000000”
STS	Synchronization Trigger Setup	Synchronization trigger condition	The setting at the last time when a instruction to save a file in the flash ROM was issued is read from the flash ROM and set as the initial value.
PLC	Plus Limit Coordinates	Plus limit coordinates	
MLC	Minus Limit Coordinates	Minus limit coordinates	
PG1	Property Group 1	Speed range Speed transition curve Peak Keep Time Do3 watchdog timer	
PG2	Property Group 2	Selection of various options	
P2I	Port 2 Invert	Port 2 logical invert setting	
P2C	Port 2 Control	Port 2 control	“0x000000”
WA	Write Assist	Assist data	“0x000000”

The value of registers TPC, RAD, LS, US, ACC, which are parameters directly necessary for axis operation, are read into the pattern memory corresponding to the axis from the flash ROM installed in MKY44-MC01A. Then, the “No = 0” data of the pattern memory corresponding to the axis is set as the initial value.

Also, the various settings of STS, PLC, MLC, PG1, PG2, and P2I are read from the flash ROM and set as the initial values. These values are the data at the last time when a instruction to save a file in the flash ROM was issued.

For more information about flash ROM and pattern memory, see **“1.6 Pattern Memory and File”**.

2.3 Commands of MKY44-MC01A

This section describes the commands of MKY44-MC10A.

User applications can operate MKY44-MC01A by issuing commands. These commands are classified into commands to operate motion (MC), commands to operate general-purpose Do pins (Do), commands to set data in a write-protected register (WR), and commands to operate pattern memory (PM) (see Table 2-11).

Table 2-11 List of Commands

Code	Command name	Instruction description		Reference	Type
0x00	clear	Clear a command		---	---
0x01	Quick_Stop	Stop immediately		1.2 Basic Instructions	MC
0x02	LFlat	Constant speed with lower speed			
0x03	UFlat	Constant speed with upper speed			
0x04	P_Acceleration	Acceleration			
0x05	M_Acceleration	Deceleration			
0x06	MA_Stop	Deceleration stop			
0x07	DS_Pattern	Distance specification pattern movement			
0x08	DS_LFlat	Distance specification lower speed movement			
0x09	DS_UFlat	Distance specification upper speed movement			
0x0A	TS_Pattern	Target specification pattern movement		1.3.2 Move Instruction to Specify Target	
0x0B	TS_LFlat	Target specification lower speed movement			
0x0C	TS_UFlat	Target specification upper speed movement			
0x0D	OriginSearch_1	Origin search 1		1.4 Origin Detection	
0x0E	OriginSearch_2	Origin search 2			
0x0F	OriginSearch_3	Origin search 3			
0x10	CW	Plus direction		1.2 Basic Instructions	
0x11	CCW	Minus direction			
0x12	DoWrite	Do data write		1.9.2 General-Purpose Input Pins/ General-Purpose Output Pins	Do
0x13	m.r.	Reserved by manufacturer		---	---
0x14					
0x15					
0x16	LPCwrite	LPC	Register write	2.2.3.2 Description of Register LPC	WR
0x17	PPCwrite	PPC		2.2.3.3 Description of Register PPC	
0x18	STSwrite	STS		2.2.3.11 Description of Register STS	
0x19	PLCwrite	PLC		2.2.3.12 Description of Registers PLC and MLC	
0x1A	MLCwrite	MLC		2.2.3.13 Description of Register PG1	
0x1B	PG1write	PG1			
0x1C	PG2write	PG2			
0x1D	patternRead	Read from pattern memory		1.6 Pattern Memory and File	PM
0x1E	patternWrite	Write in pattern memory			
0x1F	patternSave	Save pattern in file			

User applications can issue commands by writing the code shown in Table 2-11 in bits 20 to 16 of the COM register (see Figure 2.4, Figure 2.5, and Table 2-2). You can write “0x00” to the command code. MKY44-MC01A will not operate for the command code “0x00”. The command codes from “0x13” to “0x15” are manufacturer-reserved. User applications shall not issue these codes.

2.3.1 Commands to Control Motion

The command codes from “0x01” to “0x11” are for motion control. Among these, codes from “0x02” to “0x0F” may require parameters. MKY44-MC01A uses the data set in each register as parameters at the point when these commands are issued. Therefore, set necessary parameters before issuing commands.

2.3.2 Commands to Set Data in General-Purpose Output Pins

The command code “0x12” is a DoWrite command that operates general-purpose output pins Do0 to Do3. To issue this command, write the data to set to the Do pins in the DOP (Data Out port) bits of register COM, bits 7 to 4, at the same time.

If the Do3 Watchdog (Do3W) value of the PG1 (Property Group 1) register is set as “0x00”, pin Do3 will function as a normal general-purpose Do pin. Thus, the Do3 bit data in the 4-bit data to output to the general-purpose Do pins can be written to pin Do3.

When the Do3 Watchdog (Do3W) value of the PG1 register is set otherwise than as “0x00”, you cannot write “0” in the bit of pin Do3 if pin Do3 is “1” and the axis is still operating. You can write “0” when the axis is stopped. The status of the axis can be referred to by the MS (Motion Status) bit of the AXS, COM, and SCom registers. For more information about the Do3 Watchdog, see **“1.9.4 Do3 Watchdog Timer Function”**.

If the “axis operating signal” is selected as the signal to output to pin Do2 by the Do2FS (Do2 Function Select) bit of the PG2 (Property Group 2) register, the Do2 bit data of the register COM to output to the general-purpose Do pins will not be written in pin Do2. For more information about the “axis operating signal”, see **“1.9.3 Output Signal Indicating Axis Operating”**.

For operation to set the data in pins Do20 to Do23 of general-purpose output port 2, see **“2.2.3.15 Description of Register P2C”**.

2.3.3 Data Setting Commands for Write-Protected Registers

The command codes 0x16 to 0x1C are commands to set data in write-protected registers. These commands are received only while the axis is stopped.

Before issuing these command, set the data to write in register WA. These commands will not be received and will cause an error unless they are issued in the next operation after writing the data in register WA.

2.3.4 Operation Commands of Pattern Memory

When issuing the patternRead (0x1D) command to the COM register, you should write the target pattern memory number in the pattern number (bits 12 to 8) in the same COM register at the same time.

When MKY44-MC01A receives this command, it sets the pattern memory data of the specified number as parameters in registers TPC, RAD, LS, US, and ACC.

When issuing the patternWrite (0x1E) command to the COM register, you should write the target pattern memory number in the pattern number (bits 12 to 8) in the same COM register at the same time.

When MKY44-MC01A receives this command, it stores the data of registers TPC, RAD, LS, US, and ACC in the pattern memory of the specified number.

If the patternSave (0x1F) command is issued to the COM register, MKY44-MC01A will save the pattern memory in the flash ROM as one file. The file includes the data of registers STS, PLC, MLC, PG1, and PG2.

Thus saving the file in the flash ROM with the patternSave (0x1F) command requires the time of approximately 1 second. Other functions of MKY44-MC01A will stop during the process. Therefore, this instruction will not be received while the axis is operating.

MKY44-MC01A does not have commands to read the file saved in the flash ROM.

The file saved in the flash ROM is read from the flash ROM when MKY44-MC01A returns from the reset state due to power-on or such. The file read from it is used to set the data of pattern memory and registers STS, PLC, MLC, PG1, PG2, and P2I. For details, see “**2.2.4 Initial Values of Registers**”.



While MKY44-MC01A is saving a file in flash ROM, physical position coordinates also cannot be controlled. Therefore, it is recommended to save the file when you can confirm that the input signal of physical position coordinates is also static.

2.3.5 Synchronization Commands

User applications can synchronize the basic instructions and move instructions shown in Table 2-12. The codes and commands shown in Table 2-12 are the same as the codes (0x00 to 0x0C) shown in Table 2-11.

To synchronize instructions, write the codes shown in Table 2-12 in the SCom bits (bits 19 to 16) of the SCom register. When preparation for synchronization is complete, “1” is shown in the SR (Synchronization Ready) flag. For more on synchronization of instructions, see **“1.7 Synchronization of Operation Instructions”**.

Since the clear of code = 0x00 is only to clear a command, it is not a synchronization instruction.

Table 2-12 List of Synchronization Commands

Code	Command name	Instruction description	Reference	Type
0x00	clear	Clear a command	---	---
0x01	Quick_Stop	Stop immediately	1.2 Basic Instructions	MC
0x02	LFlat	Constant speed with lower speed		
0x03	UFlat	Constant speed with upper speed		
0x04	P_Accele	Acceleration		
0x05	M_Accele	Deceleration		
0x06	MA_Stop	Deceleration stop		
0x07	DS_Pattern	Distance specification pattern movement		
0x08	DS_LFlat	Distance specification lower speed movement		
0x09	DS_UFlat	Distance specification upper speed movement		
0x0A	TS_Pattern	Target specification pattern movement	1.3.2 Move Instruction to Specify Target	
0x0B	TS_LFlat	Target specification lower speed movement		
0x0C	TS_UFlat	Target specification upper speed movement		

2.4 Errors and Error Notification

When an error occurs after a user application writes a command to MKY44-MC01A, MKY44-MC01A reports the occurrence of an error to the user application and makes a transition to the “error notification state” by setting “0x3D” in the ASB (Answer Status Byte). For more on the “error notification state” and its cancellation, see “2.1.5.3 Error Notification”.

Table 2-13 shows the error codes that are set in the most significant byte of Read Data in the “error notification state”.

Table 2-13 List of Error Codes

Code	Error description
0x00	None
0x01	The command cannot be received because the register has no bit to be written.
0x02	The command cannot be received, because deceleration stop is selected in the STS (Stop Type Select) bit of PG2 and the write is to a register that is write-protected while the axis is operating.
0x03	The command cannot be received because the value of LS (Lower Speed) register is inappropriate for the speed range.
0x04	The command cannot be received because the value of US (Upper Speed) register is inappropriate for the speed range.
0x05	The command cannot be received because the difference between the LS (Lower Speed) register value and US (Upper Speed) register value (speed transition width) is less than the specified value of 32 pps.
0x06	The command cannot be received because the difference between the NS (Now Speed) register value and US (Upper Speed) register value (speed transition width) is less than the specified value of 32 pps.
0x07	The command cannot be received because the difference between the NS (Now Speed) register value and LS (Lower Speed) register value (speed transition width) is less than the specified value of 32 pps.
0x08	The command cannot be received because the plus acceleration value of the ACC (ACCEleration) register is less than the settable lower limit.
0x09	The command cannot be received because the plus acceleration value of the ACC (ACCEleration) register is more than the settable upper limit.
0x0A	The command cannot be received because the climbing time value of the ACC (ACCEleration) register is less than the settable lower limit.
0x0B	The command cannot be received because the falling time value of the ACC (ACCEleration) register is less than the settable lower limit.
0x0C	The command cannot be received because the minus acceleration value of the ACC (ACCEleration) register is less than the settable lower limit.
0x0D	The command cannot be received because the minus acceleration value of the ACC (ACCEleration) register is more than the settable upper limit.
0x0E	The data setting command to the write-protected register cannot be received unless it is right after WA (Write Assist) write.
0x0F	The command cannot be received because it is not supported by MKY44-MC01A.
0x10	The command cannot be received because it cannot be executed while the axis is operating.
0x11	The command cannot be received because it cannot be executed during operation by the pattern move instruction.
0x12	The command cannot be received because it cannot be executed while stopped or decelerating.
0x13	The command cannot be received because it cannot be executed during deceleration stop suspension.
0x14	The command cannot be received because it cannot be executed during deceleration stop.

Table 2-13 List of Error Codes

Code	Error description
0x15	The command cannot be received because it cannot be executed during acceleration.
0x16	The command cannot be received because it cannot be executed while stopped.
0x17	The command cannot be received because it cannot be executed unless stopped.
0x18	The command cannot be received because it cannot be written to the synchronization command.
0x19	The command cannot be received because it is a synchronization command that cannot be addressed during deceleration.
0x1A	The command cannot be received because it is a synchronization command that cannot be addressed unless at constant speed.
0x1B	The command cannot be executed during manual operation.
0x1C	---
0x1D	
0x1E	
0x1F	
0x20	Cannot operate because the hardware limit of the specified direction is already ON.
0x21	Cannot operate because the limit coordinate of the specified direction has been reached.
0x22	Cannot operate because the stop sensor (Di3,2) of the specified direction is already ON.
0x23	Cannot operate because the origin sensor is already ON.
0x24	Cannot operate because the EZ (Encoder Zero) sensor (Di0) is already ON.
0x25	Cannot operate because SCD03 (Start Condition with Do3) of the PG2 register is set ON and the data bit of Do3 is "0".
0x26	Cannot operate because stop signal input (Di1) is already ON.
0x27	The command cannot be executed because the all stop input pin is active.
0x28	The command cannot be executed because it is a move instruction whose distance is "0".
0x29	The command cannot be executed because OSE (OverScale Enable) in the PG2 register is disabled and the target position coordinate calculated from the distance exceeds the range that can be controlled by logical position coordinates.
0x2A	The command cannot be executed because the specified distance falls short of pattern formation and the pattern reduction function is OFF.
0x2B	The command cannot be executed because the specified distance falls short of pattern formation including Peak Keep Time for triangular drive prevention and the pattern reduction function is OFF.
0x2C	A command that originates triangular drive cannot be executed because it is during Peak Keep Time after completing acceleration.
0x2D	A command that originates triangular drive cannot be executed because it is during Peak Keep Time after completing deceleration or deceleration stop.
0x2E	---
0x2F	
0x30	File save instruction to flash ROM (patternSave command) cannot be received during axis operation.
0x31	File save in flash ROM failed (flash ROM hardware failure detected).

2.5 Motion Events

If the stop sensor turns OFF after the axis stops after turning ON the stop sensor, it is impossible to understand why it stops just by referring to MS (Motion Status). In such a case, it is easier to create applications if the events related to operation start and stop of motion are kept. MKY44-MC01A provides the events (changes of operation are not considered as events) related to operation start and stop of motion in ME (bits 20 to 16) of the AXS register as the codes shown in Table 2-14.

ME in the AXS register will not disappear until the next event occurs or a user application writes the clear code (0x00), except in return from reset.

Table 2-14 List of Motion Event Codes

Code	Event name	Description	Reference/remark	Type	
0x00	clear	Clear event codes	Write from user applications	---	
0x01	Free_Start	Start by lower speed, upper speed, and acceleration instructions	1.2 Basic Instructions	Start	
0x02	Target_Start	Start by DS_LFlat, DS_UFlat, TS_LFlat, and TS_UFlat instructions	1.3 Move Instructions		
0x03	Pattern_Start	Start by DS_Pattern and TS_Pattern instructions			
0x04	OriginSearch_Start	Origin search start	1.4 Origin Detection		
0x05	Manual_Start	Manual start	1.8 Addressing Manual Operation		
0x06	Correction_Free_Start	Parameter auto correction	Start by lower speed, upper speed, and acceleration instructions	1.2 Basic Instructions	Start
0x07	Correction_Target_Start		Start by DS_LFlat, DS_UFlat, TS_LFlat, and TS_UFlat instructions	1.3 Move Instructions	
0x08	Correction_Pattern_Start		Start by DS_Pattern and TS_Pattern instructions		
0x09	Correction_OriginSearch_Start		Origin search start	1.4 Origin Detection	
0x0A	Correction_Manual_Start		Manual start	1.8 Addressing Manual Operation	
0x0B to 0x0F		Reserved by manufacturer	---	---	
0x10	Do3WatchdogTimeOver	Do3 clear generated by Do3 watchdog timer	1.9.4 Do3 Watchdog Timer Function		
0x11	Command_Stop	Stop by stop command	1.2 Basic Instructions	Stop	
0x12	Command_Normal_Stop	Stop by command normal completion	1.9.2 General-Purpose Input Pins/ General-Purpose Output Pins		
0x13	ManualEnd_Stop	Stop by manual operation completion	1.8 Addressing Manual Operation		
0x14	DONA	DONA occurred in the past	1.9.6 Addressing DONA and Network Failure		
0x15, 0x16		Reserved by manufacturer	---	---	
0x17	OriginTurnOn_Stop	Stop by detecting OFF ⇒ ON of origin sensor	1.4 Origin Detection 1.5 Stop Functions	Stop	
0x18	OriginTurnOff_Stop	Stop by detecting ON ⇒ OFF of origin sensor			
0x19	EZ_LoSignal_Stop	Stop by detecting ON of EZ sensor			
0x1A	StopSignal_Stop	Stop by stop signal (Di1) input			
0x1B	LimitCoordinates_Stop	Stop by reaching the limit coordinate	1.5.6 Stop Setting Using Limit Coordinates		
0x1C	StopSensor_Stop	Stop by detecting stop sensor (Di2,3) ON	1.5 Stop Functions		
0x1D	HardLimit_Stop	Stop by detecting hardware limit ON	1.5 Stop Functions		
0x1E	DONA_Stop	Stop by DONA occurrence	1.5.1 All Stop 1.5.2 DONA Stop 1.9.6 Addressing DONA and Network Failure		
0x1F	All_stop	Stop by all stop signal input	1.5.1 All Stop		

2.6 Exceptional Operation

User applications can perform hardware reset on MKY44-MC01A by executing the following special operation to the network if CUnet confirms the connection of MKY44-MC01A.

To reset MKY44-MC01A remotely, write the specified 8-byte data in the TMC (area To Motion Controller) specified by DOSA as shown in Figure 2.6. For more information about TMC (area To Motion Controller), see **“2.1 How to Access CUnet Interface and Registers”**.

TMC relative address	+0	+1	+2	+3	+4	+5	+6	+7
The data to set	0x15	0x7A	0x92	0xEF	0x92	0x7A	0x15	0xAF

Fig. 2.6 Data Format of Remote Reset

After performing hardware reset, MKY44-MC01A transitions to the operation described in **“2.1.5.1 Reset Warning State and How to Cancel It”**.



Use the remote reset of MKY44-MC01A only when it is intended by the user application, such as in system initialization.

2.7 Operation Procedure of MKY44-MC01A

It is recommended to use MKY44-MC01A by the following operation procedure.

- (1) Process after power-on and return from reset
- (2) Confirming chip codes
- (3) Initializing the registers for motion control
- (4) Initializing the application device
- (5) Normal operation
- (6) Exit operation

2.7.1 Process after Power-on and Return from Reset

Power on MKY44-MC01A after confirming that peripheral hardware and the communication line of CUnet are properly connected.

MKY44-MC01A enters the “reset warning state” when returning from the reset state due to power-on or hardware reset. User applications need to cancel the state after confirming that MKY44-MC01A is in the reset warning state. For the details on the “reset warning state”, see **“2.1.5.1 Reset Warning State and How to Cancel It”**.

If the option described in **“2.1.6 Extended CUnet Interface (Optional)”** is selected, “all MAWs” as described in **“2.1.5.1 Reset Warning State and How to Cancel It”** and **“2.1.5.2 CUnet Line Return Warning and How to Cancel It”** represents four MAWs (MAW0 to MAW3). Likewise, “all MCWs” represents four MCWs (MCW0 to MCW3). Therefore, the user application should prepare 16 bytes of cancel codes to cancel them.

2.7.2 Confirming Chip Codes

Read CC (Chip Code) from MKY44-MC01A and confirm if it is normal. If the operation of the user application program differs by version number, make sure for it. By performing read access to registers number “0x21 to 0x24”, one can confirm CC (Chip Code) as the little-endian ASCII string “MKY44MC01Ann” (see Figure 2.4). The chip code is “MKY44MC01A” and the value of last two digits represents the version number.

2.7.3 Initializing the Registers for Motion Control

For the initial values of the registers for motion control, which are initialized after return from reset, see “**2.2.4 Initial Values of Registers**”. If the user applications use these values as initial values, no operation will be necessary in this step.

If the user application must change these values, set the initial values. Regarding writing of registers, see “**2.2.1 Register Structure of Motion Control and Port 2 Control**” and “**2.2.2 Write-Protected Registers**”.

2.7.4 Initializing the Application Device

The functions for motion control of MKY44-MC01A such as “setting parameters to instruct operation” or “calling a pattern from pattern memory to instruct operation” can be used from this step.

If you need initializing operation that is unique to the application device, such as finding the origin and moving the arm to the origin, it is recommended to execute this step. For some applications, the initialization of the coordinate system in MKY44-MC01A can be done only in this step. Execute initializing operation suitable for the user application. If an error or a warning occurs along the way, execute a process suitable for the application according to the process described in “**2.1.5 Warnings and Notifications from MKY44-MC01A**”.

2.7.5 Normal Operation

Access the registers for motion control and perform normal operation suitable for the user application by “setting parameters to instruct operation” or “calling patterns from pattern memory to instruct operation”. If an error or a warning occurs along the way, execute a process suitable for the application according to the process described in “**2.1.5 Warnings and Notifications from MKY44-MC01A**”.

2.7.6 Exit Operation

The values of LPC (Logical Position Coordinates) and PPC (Physical Position Coordinates) in MKY44-MC01A will disappear after the power is turned off.

Also, when MKY44-MC01A returns from reset, the value of these registers will be initialized to “0”.

When controlling coordinates by using LPC (Logical Position Coordinates) and PPC (Physical Position Coordinates) for applications that control the coordinates of slide tables and such, if power-off or reset is performed when the coordinate position is not “0”, the workload of the user application to correct the coordinate in the next startup may increase.

Before the power-off or reset of MKY44-MC01A, it is recommended to perform “exit operation”, such as moving back a target that requires coordinate control to the coordinate “0”, just like the shutdown or restart operation of PC.

2.8 Addressing CUnet Mail Function

MKY44-MC01A supports a product type inquiry function via CUnet mail function. If MKY44-MC01A receives the following “product type inquiry format” mail, it will respond by sending a “response format” mail. This “product type inquiry” can be called from any device on CUnet. If there is a mistake in even one character of the “product type inquiry format”, MKY44-MC01A will send back a “response format” with not “M”, meaning Master code, but “N” (0x4C), meaning NAC code, as MS (Message Status).

● Product type inquiry format

Byte Count	0x00	0x01	0x02	0x03	0x04	0x05	0x06	0x07
Contents	CUnet ?[CR]							
ASCII	C	U	n	e	t		?	[CR]
HEX	43	55	6E	65	74	20	3F	0D

All bytes 0x00 to 0x06 are fixed ASCII character strings.

Byte 0x07 showing [CR] is “0x0D”, of the fixed ASCII character standard.

● Response format

Byte Count	0x00	0x01	0x02	0x03	0x04	0x05	0x06	0x07	0x08	0x09	0x0A	0x0B	0x0C	0x0D	0x0E	0x0F
Contents	Identity Code								MS	MC	BPS SA	Hopt DOSA	---	---	---	---
	Name				Ver											
ASCII	M	C	0	1	A		*	*	'M'	.	*	*
HEX	4D	43	30	31	41	20	*	*	4D	00	*	*	00	00	00	00

In bytes 0x00 to 0x04, the product type is shown by ASCII characters.

In bytes 0x05, a space (ASCII character 0x20) is shown.

In bytes 0x06 and 0x07, the version number is shown as a 2-digit decimal number in ASCII characters.

Example: Ver01 is “01”. The maximum is “99”.

MS (Message Status) of byte 0x08 is normally ASCII character “M” showing normal response to “product type inquiry”.

For abnormal “product type inquiry”, it shows “N”.

In MC (Message Code) of byte 0x09, byte 0x00, representing “Basic setting”, is shown.

In BPS and SA of byte 0x0A, the transfer rate (BPS) and SA of the hardware setting status are shown in hexadecimal.

This value matches what DIP-SW0 is when setting hardware by hexadecimal setting specifications.

Regarding hardware setting, see **“3.4.3 Connection of Signal for Hardware Setting (Hexadecimal Setting Specifications)”**.

In Hopt and DOSA of byte 0x0B, the value of the hardware options (HOPT1, HOPT0) and DOSA is shown in hexadecimal.

This value matches what DIP-SW1 is when setting hardware by hexadecimal setting specifications.

Regarding hardware setting, see **“3.4.3 Connection of Signal for Hardware Setting (Hexadecimal Setting Specifications)”**.

In bytes 0x0C to 0x0F, “0x00” is shown.

Identity Code (composed of bytes 0x00 to 0x07s) is the center of the product type inquiry function via CUnet mail. By referring to Identity Code, you can search for what device with what function exists in which address. Also, from the hardware setting of bytes 0x0A and 0x0B, you can understand the operation handling of the functional unit to some extent.

Appendix

Appendix 1	CUnet Cycle Time Table.....	App-3
Appendix 2	File Contents of Flash ROM in Factory Default Setting.....	App-4

Appendix 1 CUnet Cycle Time Table

(unit: μ s)

FS	Typ. (LF = 0)			Frame option (LF = 1)		
	12 Mbps	6 Mbps	3 Mbps	12 Mbps	6 Mbps	3 Mbps
1 (01h)	102.00	204.00	408.00	172.00	344.00	688.00
2 (02h)	128.33	256.67	513.33	215.83	431.67	863.33
3 (03h)	155.00	310.00	620.00	260.00	520.00	1,040.00
4 (04h)	182.00	364.00	728.00	304.50	609.00	1,218.00
5 (05h)	209.33	418.67	837.33	349.33	698.67	1,397.33
6 (06h)	237.00	474.00	948.00	394.50	789.00	1,578.00
7 (07h)	265.00	530.00	1,060.00	440.00	880.00	1,760.00
8 (08h)	293.33	586.67	1,173.33	485.83	971.67	1,943.33
9 (09h)	322.00	644.00	1,288.00	532.00	1,064.00	2,128.00
10 (0Ah)	351.00	702.00	1,404.00	578.50	1,157.00	2,314.00
11 (0Bh)	380.33	760.67	1,521.33	625.33	1,250.67	2,501.33
12 (0Ch)	410.00	820.00	1,640.00	672.50	1,345.00	2,690.00
13 (0Dh)	440.00	880.00	1,760.00	720.00	1,440.00	2,880.00
14 (0Eh)	470.33	940.67	1,881.33	767.83	1,535.67	3,071.33
15 (0Fh)	501.00	1,002.00	2,004.00	816.00	1,632.00	3,264.00
16 (10h)	532.00	1,064.00	2,128.00	864.50	1,729.00	3,458.00
17 (11h)	563.33	1,126.67	2,253.33	913.33	1,826.67	3,653.33
18 (12h)	595.00	1,190.00	2,380.00	962.50	1,925.00	3,850.00
19 (13h)	627.00	1,254.00	2,508.00	1,012.00	2,024.00	4,048.00
20 (14h)	659.33	1,318.67	2,637.33	1,061.83	2,123.67	4,247.33
21 (15h)	692.00	1,384.00	2,768.00	1,112.00	2,224.00	4,448.00
22 (16h)	725.00	1,450.00	2,900.00	1,162.50	2,325.00	4,650.00
23 (17h)	758.33	1,516.67	3,033.33	1,213.33	2,426.67	4,853.33
24 (18h)	792.00	1,584.00	3,168.00	1,264.50	2,529.00	5,058.00
25 (19h)	826.00	1,652.00	3,304.00	1,316.00	2,632.00	5,264.00
26 (1Ah)	860.33	1,720.67	3,441.33	1,367.83	2,735.67	5,471.33
27 (1Bh)	895.00	1,790.00	3,580.00	1,420.00	2,840.00	5,680.00
28 (1Ch)	930.00	1,860.00	3,720.00	1,472.50	2,945.00	5,890.00
29 (1Dh)	965.33	1,930.67	3,861.33	1,525.33	3,050.67	6,101.33
30 (1Eh)	1,001.00	2,002.00	4,004.00	1,578.50	3,157.00	6,314.00
31 (1Fh)	1,037.00	2,074.00	4,148.00	1,632.00	3,264.00	6,528.00
32 (20h)	1,073.33	2,146.67	4,293.33	1,685.83	3,371.67	6,743.33
33 (21h)	1,110.00	2,220.00	4,440.00	1,740.00	3,480.00	6,960.00
34 (22h)	1,147.00	2,294.00	4,588.00	1,794.50	3,589.00	7,178.00
35 (23h)	1,184.33	2,368.67	4,737.33	1,849.33	3,698.67	7,397.33
36 (24h)	1,222.00	2,444.00	4,888.00	1,904.50	3,809.00	7,618.00
37 (25h)	1,260.00	2,520.00	5,040.00	1,960.00	3,920.00	7,840.00
38 (26h)	1,298.33	2,596.67	5,193.33	2,015.83	4,031.67	8,063.33
39 (27h)	1,337.00	2,674.00	5,348.00	2,072.00	4,144.00	8,288.00
40 (28h)	1,376.00	2,752.00	5,504.00	2,128.50	4,257.00	8,514.00
41 (29h)	1,415.33	2,830.67	5,661.33	2,185.33	4,370.67	8,741.33
42 (2Ah)	1,455.00	2,910.00	5,820.00	2,242.50	4,485.00	8,970.00
43 (2Bh)	1,495.00	2,990.00	5,980.00	2,300.00	4,600.00	9,200.00
44 (2Ch)	1,535.33	3,070.67	6,141.33	2,357.83	4,715.67	9,431.33
45 (2Dh)	1,576.00	3,152.00	6,304.00	2,416.00	4,832.00	9,664.00
46 (2Eh)	1,617.00	3,234.00	6,468.00	2,474.50	4,949.00	9,898.00
47 (2Fh)	1,658.33	3,316.67	6,633.33	2,533.33	5,066.67	10,133.33
48 (30h)	1,700.00	3,400.00	6,800.00	2,592.50	5,185.00	10,370.00
49 (31h)	1,742.00	3,484.00	6,968.00	2,652.00	5,304.00	10,608.00
50 (32h)	1,784.33	3,568.67	7,137.33	2,711.83	5,423.67	10,847.33
51 (33h)	1,827.00	3,654.00	7,308.00	2,772.00	5,544.00	11,088.00
52 (34h)	1,870.00	3,740.00	7,480.00	2,832.50	5,665.00	11,330.00
53 (35h)	1,913.33	3,826.67	7,653.33	2,893.33	5,786.67	11,573.33
54 (36h)	1,957.00	3,914.00	7,828.00	2,954.50	5,909.00	11,818.00
55 (37h)	2,001.00	4,002.00	8,004.00	3,016.00	6,032.00	12,064.00
56 (38h)	2,045.33	4,090.67	8,181.33	3,077.83	6,155.67	12,311.33
57 (39h)	2,090.00	4,180.00	8,360.00	3,140.00	6,280.00	12,560.00
58 (3Ah)	2,135.00	4,270.00	8,540.00	3,202.50	6,405.00	12,810.00
59 (3Bh)	2,180.33	4,360.67	8,721.33	3,265.33	6,530.67	13,061.33
60 (3Ch)	2,226.00	4,452.00	8,904.00	3,328.50	6,657.00	13,314.00
61 (3Dh)	2,272.00	4,544.00	9,088.00	3,392.00	6,784.00	13,568.00
62 (3Eh)	2,318.33	4,636.67	9,273.33	3,455.83	6,911.67	13,823.33
63 (3Fh)	2,365.00	4,730.00	9,460.00	3,520.00	7,040.00	14,080.00

Appendix 2 File Contents of Flash ROM in Factory Default Setting

The following are the contents written in the flash ROM at factory shipping as the initial values set in the pattern memory of the axis when returning from hardware reset.

Pattern Number		Target position coordinate TPC	Relative distance RD	Lower speed LS	Upper speed US	Acceleration pps/10 ms		Reference value pps/sec.		Remarks
Od	Ox					Acceleration	Deceleration	Acceleration	Deceleration	
0	00	1,000	1,000	160	2,500	200	200	20k	20k	Natural acceleration
1	01	-1,000	-1,000	160	2,500	200	200	20k	20k	Same as above. The distance is minus.
2	02	17,000	17,000	160	2,500	200	2	20k	200	Rapidly accelerate and then decelerate 100 times slower.
3	03	-17,000	-17,000	160	2,500	200	2	20k	200	Same as above. The distance is minus.
4	04	17,000	17,000	160	2,500	2	200	200	20k	Accelerate 100 times slower and then rapidly decelerate.
5	05	-17,000	-17,000	160	2,500	2	200	200	20k	Same as above. The distance is minus.
6	06	30,000	30,000	160	24,000	200	200	20k	20k	Accelerate to the maximum speed with natural acceleration.
7	07	-30,000	-30,000	160	24,000	200	200	20k	20k	Same as above. The distance is minus.
8	08	160,000	160,000	160	24,000	200	20	20k	2k	Naturally accelerate to the maximum speed and then decelerate 10 times slower.
9	09	-160,000	-160,000	160	24,000	200	20	20k	2k	Same as above. The distance is minus.
10	0A	160,000	160,000	160	24,000	20	200	2k	20k	Accelerate 10 times slower to the maximum speed and then naturally decelerate.
11	0B	-160,000	-160,000	160	24,000	20	200	2k	20k	Same as above. The distance is minus.
12	0C	12,000	12,000	160	24,000	2644	2644	264k	264k	Accelerate most rapidly to the maximum speed.
13	0D	-12,000	-12,000	160	24,000	2644	2644	264k	264k	Same as above. The distance is minus.
14	0E	13,000	13,000	160	24,000	2644	265	264k	26k	Accelerate rapidly to the maximum speed and then decelerate 10 times slower.
15	0F	-13,000	-13,000	160	24,000	2644	265	264k	26k	Same as above. The distance is minus.
16	10	13,000	13,000	160	24,000	265	2644	26k	264k	Accelerate 10 times slower to the maximum speed and then decelerate rapidly.
17	11	-13,000	-13,000	160	24,000	265	2644	26k	264k	Same as above. The distance is minus.
18	12	1,000,000	1,000,000	160	24,000	1	1	100	100	Accelerate most slowly in 40.95 seconds.
19	13	-1,000,000	-1,000,000	160	24,000	1	1	100	100	Same as above. The distance is minus.
20	14	520,000	520,000	160	24,000	238	1	24k	100	Accelerate in a second. Decelerate most slowly in 40.95 seconds.
21	15	-520,000	-520,000	160	24,000	238	1	24k	100	Same as above. The distance is minus.
22	16	520,000	520,000	160	24,000	1	238	100	24k	Accelerate most slowly in 40.95 seconds. Decelerate in a second.
23	17	-520,000	-520,000	160	24,000	1	238	100	24k	Same as above. The distance is minus.
24	18	35,000	35,000	10	2,500	2	2	200	200	Operating from ultra-low speed. Slow acceleration and deceleration.
25	19	-35,000	-35,000	10	2,500	2	2	200	200	Same as above. The distance is minus.
26	1A	17,000	17,000	10	2,500	60	2	6k	200	Operating from ultra-low speed. The ratio of acceleration and deceleration is 30:1.
27	1B	-17,000	-17,000	10	2,500	60	2	6k	200	Same as above. The distance is minus.
28	1C	17,000	17,000	10	2,500	2	60	200	6k	Operating from ultra-low speed. The ratio of acceleration and deceleration is 1:30.
29	1D	-17,000	-17,000	10	2,500	2	60	200	6k	Same as above. The distance is minus.
30	1E	70,000	70,000	160	24,000	100	100	10k	10k	Natural acceleration and deceleration. Addressing triangular drive prevention of 500 ms.
31	1F	0	2,000	2,000	2,500	50	50	5k	5k	Addressing manual parameters.

The following are the contents written in flash ROM at factory shipping as the initial values set in the registers when returning from hardware reset.

Register		Target function	Set value	Value in flash ROM (24 Bit Data)
Abbreviation	Name			
STS	Synchronization Trigger Setup	Address of synchronization trigger	0x000	0x0000FB
		Data of synchronization trigger	0xFB	
PLC	Plus Limit Coordinates	Plus limit coordinates	+8,300,000	0x7EA5E0
MLC	Minus Limit Coordinates	Minus limit coordinates	-8,300,000	0x815A20
PG1	Property Group 1	Speed range	2 (10)	0x009000 See "2.2.3.13 Description of Register PG1"
		Speed transition curve	1 (S-curve)	
		Peak Keep Time	0	
		Do3 watchdog timer	0	
PG2	Property Group 2	Selection of various options	---	0xC08500 See "2.2.3.14 Description of Register PG2"
P2I	Port 2 Invert	Port 2 logical invert	0x00	0x000000 See "2.2.3.16 Description of Register P2I"

Revision history

Ver.	Revision date	Page	Revision contents
1.4	JAN, 2024		Change of address

■ Developed and manufactured by

StepTechnica Co., Ltd.

1-1-15 Tateno, Higashiyamato-shi, Tokyo 207-0021

TEL: 042-569-8577

<https://www.steptecnica.com/>

info@steptecnica.com

**Motion control function LSI for CUnet
MKY44-MC01A User's Manual**

Document No.: STD_MKY44MC01A_V1.4E

Issued: January 2024